

PRODUCTS CATALOG
COMMERCIAL AND INDUSTRIAL

CMP
Century
motors
Producer

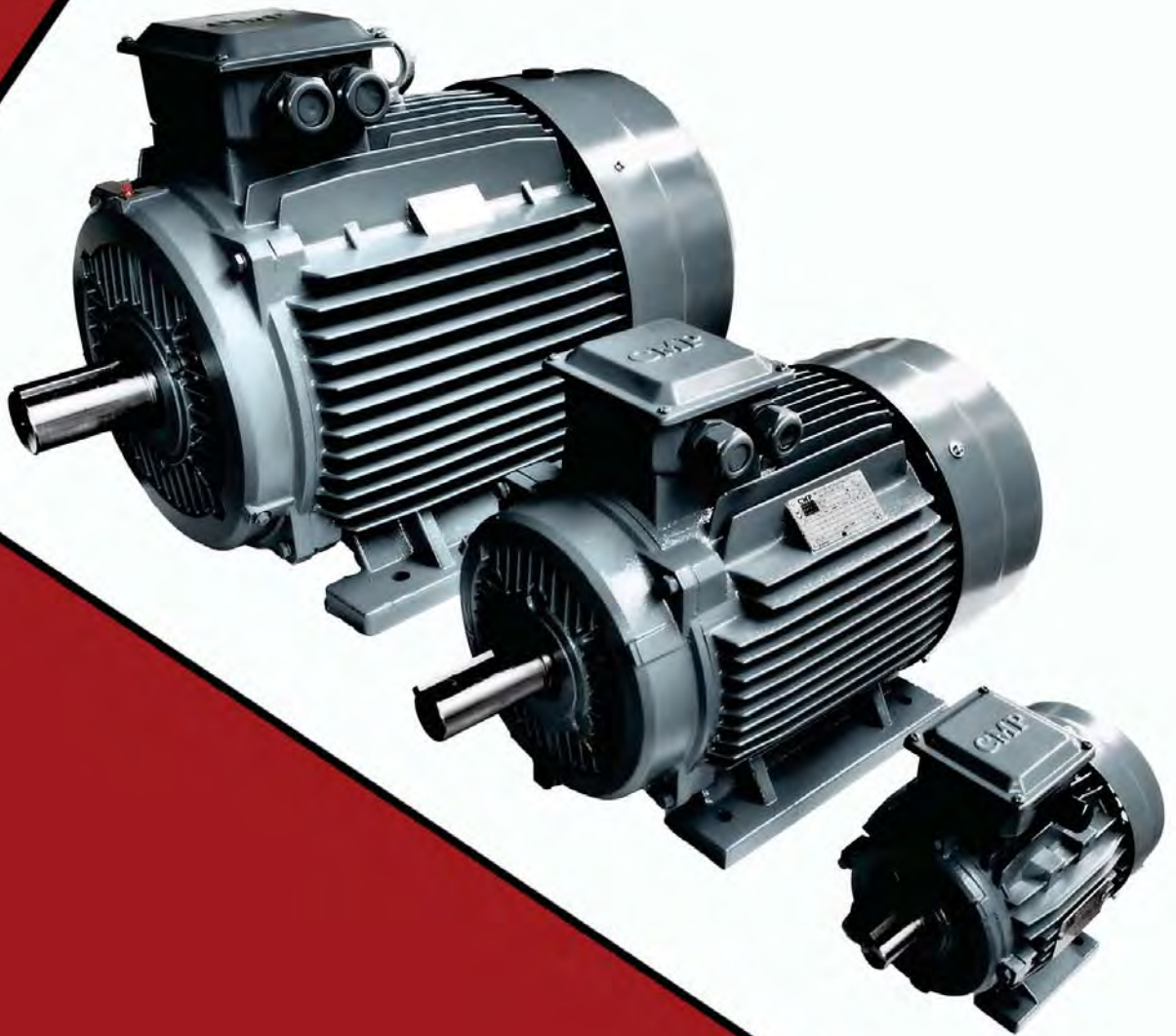

DBA SERIES
ELECTRIC MOTOR

Company Profile

CMP (Century Motors Producer) is a company made by professionals with vast experience in designing of three-phase asynchronous, smoke spill & synchronous motor. Our comprehensive range of motors has been specifically design to meet the diverse requirements and needs of our customers, offering state of the art solutions backed by outstanding application expertise.

CMP has continuously improved to meet customer expectation & the principle of CMP is to produce quality energy saving, high temperature and servo motor to cater for the most demanding market all over the world.

CMP has been using the most advanced and latest manufacturing machinery to produce its motors and the factory facilities has exceeded the expectation of our customer. Our factory has perfect management system and passed the ISO9001:2015, 3C & CE certification. CMP will continuous improve to meet the competition in the market.

CMP maintain 3 keys value in quality first, customer first & innovation first to suit the demanding product requirement for our customers all around the world.



CMP
Century
motors
Producer



Table of Contents

	Page
Products Introduction / Identification	1
Products Specifications / Parameters	2
Motor's Enclosure / Protection	
Insulation	
Protection Device	
Paint / Finishing	
Bearings	
Terminal Box and Cable Entry	
Vibration	
Electrical Specifications	6
Voltage / Frequencies	
Duty Cycles	
Temperature and Altitude	7
Connections / Diagrams	7
Starting Methods	7
Mounting Arrangements	8
Airstream Motors for Axial Flow Fans	9
Cooling Tower Motors	9
Two Speed Motors	9
Performance Data for DBA1 Series	10
Dimensional Drawing for DBA1 Series	18
Performance Data for DBA2 Series	22
Performance Data for DBA3 Series	29
Dimensional Drawing for DBA2&3 Series	35
Two Speed motor General Data	39
Motors for hazardous areas	41

General Information

CMP motors are standard TEFC (Totally Enclosed Fan Cooled) three phase asynchronous motor, designed and manufactured to meet all kinds of environmental conditions. Such as mining, petroleum, marine/offshore and any general tropical working areas.

Combined with high quality materials and stringent manufacturing inspections, **CMP** range of motors offer excellency in efficiency, starting torque, low noise and energy saving.

Type	Motor	Frame Size	KW Range	Voltage	Charecteristic & Features
DBA1	Wide Frequency Based Motor Motor IE1	71 - 355	0.37-315KW	1140V and Below	Low Noise , Less Vibration , Energy Saving ,Efficiency is slightly higher than normal IE1 Leve.I Frequency Range : 30 - 50Hz at variable torque
DBA2	High Efficiency Motor IE2	80 - 355	0.75 - 375KW	1000V and Below	Motor Efficiency Conforms to IEC 60034-30 IE2 Level
DBA3	Premium Efficiency Motor IE3	80 - 355	0.75 - 375KW	1000V and Below	Motor Efficiency Conforms to IEC 60034-30 IE3 Level
DBAM	High KW , Low Voltage Motor	355 - 450	2P 355-800KW	1140V and Below	Available at 50Hz to 60Hz
			4P 355KW - 900KW	For Frame Size	
			6P 315KW-710KW	450, the voltage is	
			8P 250KW - 560KW	690V and above	
			10P 200KW - 400KW		
DBAV	Inverter Duty Motor with Force Cooling Fan	80 - 450	0.55Kw - 900KW	1140V and Below	Frequency range: 5Hz to 100Hz , constant torque at 5Hz - 50Hz, constant power start from 50Hz, with variations for 2 Poles, 4/6/8 Poles. Please refer to catalogue for more information
DBAC	Cooling Tower Motors	71 - 355	0.37 - 315KW	1140V and Below	Available for airstream rated cooling tower
DBAH	2 Speed High Temperature airsteam motor	2/4P, 4/8P, 4/6P, 6/8P	0.37 - 176KW	690V and Below	Suitable for smokespill application. Available for 250 Degree C/2hours and 300 Degree C/2Hours
DBA1H	Single Speed				Suitable for smokespill application.
DBA2H	High Temperature	71 - 355	0.37 - 375KW	1100V and Below	Available for 250 Degree C/2hours
DBA3H	airstream motor				and 300 Degree C/2Hours
DBA*N	Non-sparking				Certification: ECM 21 ATEX-B DO52,
DBA*E	Increased Safety three phase motor (not for coal mine)	80 - 355	0.55 - 710KW	1140V and Below	ECM 21 ATEX-B DO51, Marking : Ex II 3G Ex ec IIC T3 Gc , EX II 2G Ex eb IIC T3 Gb

Note: High voltage , high premium NEMA motors (UL) and other non -standard CMP motor are available upon request.

Introduction

This catalogue details the complete range of CMP DBA series motors. Standard DBA motors are three phase squirrel cage TEFC (Totally Enclosed Fan Cooled), with IEC frame sizes from 71 to 355, with CENELEC frame allocation as standard. They combine excellent electrical characteristics with the robust strength of cast iron.

The standard design includes single speed 2,4,6 and 8 pole as well as a comprehensive selection of 2 speed motors. In addition to the standard design, the range includes:

- DBAS** - Smokespill application
- DBAC** - Cooling tower application
- DBAR** - Airstream rated for Axial flow fans
- DBAP** - Pad mount motors
- DBAN** - Non-sparking Ex nA
- DBAE** - Increased safety Ex e
- DBAtc** - Dust Proof Ex tc Zone 22
- DBAtb** - Dust Proof Ex tb Zone 21

All units are supplied with F Class insulation, with temperature rise being limited to less than 80K (unless otherwise marked). This provides the end user with a wide safety margin under general operating conditions.

In addition we also offer motors wound with H Class insulation, and temperature rise still limited to 80K.

- DBAH** - High ambient temperature application
- DBAHS** - H Class smokespill application

Additional protection is provided by installation of thermistors in all units from 160 frame upward to continuously protect the winding.

The conservative rating of CMP type DBA motors provides additional operational safeguards, ensures long unit life, and renders this series inherently suitable for most arduous mining, industrial or agricultural applications.

Standards and specifications

The main dimensions and rated outputs of CMP type DBA motors generally conform to International Standards IEC60034, IEC60072 and Australian Standard AS1359.

Efficiency

The DBA motor range exceeds requirements of European Eff 2 or Eff 1 and correspond to IE1 (Standard Efficiency) or IE2 (High Efficiency) & IE3 (Premium Efficiency) of the new international standard IEC 00034-30.

- DBA1** = IE1 (Standard Efficiency)
- DBA2** = IE2 (High Efficiency)
- DBA3** = IE3 (Premium Efficiency)

Product code specification

When placing an order the motor product code should be specified. The product code of the motor is composed in accordance with the following example:

G	3	2	00	1503	DBA	1	S	/415
1	2	3	4 - 8	9	10 - 12	13...	Suffix	

Position 1

- G** = Cast Iron frame
- A** = Aluminum frame

Position 2

- Winding design
- 3** = Standard three phase motors
- S** = 2 speed fan duty single winding
- D** = 2 speed fan duty separate windings
- T** = 2 speed constant torque single winding
- C** = 2 speed constant torque separate windings

Position 3

Number of poles

- | | | |
|----------------------|-----------------------|-----------------------|
| 2 = 2 poles | F = 2/6 poles | M = 4/12 poles |
| 4 = 4 poles | G = 2/8 poles | N = 6/8 poles |
| 6 = 6 poles | H = 2/10 poles | O = 6/10 poles |
| 8 = 8 poles | I = 2/12 poles | P = 6/12 poles |
| A = 10 poles | J = 4/6 poles | Q = 8/10 poles |
| C = 12 poles | K = 4/8 poles | R = 8/12 poles |
| E = 2/4 poles | L = 4/10 poles | S = 8/16 poles |

Positions 4 to 8

Rated power output*
(kW x 100)

* Refers to high speed for 2 speed motors

Position 9

Mounting arrangements

- | | | |
|------------------|--------------------|-------------------------------|
| 1 = V1 | 5 = B5 | 8 = B3/B14B |
| 3 = B3 | 6 = B3/B14A | 9 = B14B |
| 4 = B3/B5 | 7 = B14A | 0 = for Pad Mount only |

Positions 10 to 12

Series

- DBA1** = IE1 (Standard Efficiency)
- DBA2** = IE2 (High Efficiency)
- DBA3** = IE3 (Premium Efficiency)

Positions 13...*

Series variation

- Blank** = Standard
- C** = Cooling tower
- L** = LHS terminal box
- S** = Smokespill
- H** = H Class insulation
- P** = Pad mount
- R** = Airstream rated
- F** = Flying Leads

* Multiple letters indicate multiple variation.

Suffix

Winding design

- | | |
|----------------------------|----------------------------|
| /385 = 380V / 50Hz | /A05 = 1000V / 50Hz |
| /415 = 415V / 50Hz | /B05 = 1100V / 50Hz |
| Blank = 400V / 50Hz | /386 = 380V / 60Hz |

Specifications and Standard Compliance

- **CMP** Motor's dimensional and rated output data generally confirm to IEC 60034 and DIN42673.
- All **CMP** Motors meet the requirement for 'CE' Markings.
- Cooling method are as per IC411 specification.

Motor's Enclosure / Degree of Protection

For vertically mounted motors

- Motors to be mounted with the shaft vertically down must be provided with a suitable cover (available on request) to ensure foreign bodies are prevented from entering the motor. Special care is necessary in fitting protective covers to ensure air flow is not impeded . To maintain IP rating, special additional measures may be required to protect the motor against the ingress of water or foreign bodies. Please contact CMP for further information.

Against solar radiation

- High solar radiation will result in undue temperature rise. In these circumstances motors should be screened from solar radiation by placement of adequate sunshades which do not inhibit air flow.

Degree of protection

- Standard levels of enclosure protection for all DBA frame sizes for both motor and terminal box is IP55, with IP56, IP65 and IP66 available on request. Enclosure designations comply with IEC or AS60529. The enclosure protection required will depend upon the environmental and operational conditions within which the motor is to operate.

Insulation

Standard DBA series motors are wound with F class insulation and winding designs limit the temperature rise to 80K (unless otherwise noted) for which B Class insulation would normally be sufficient. The use of F class insulation provides an additional safety margin of 25K, as shown in the accompanying table, together with an extended operating life.

	Insulation class		
	B	F	H
Max. permissible winding temp. (°C)	130	155	180
Less ambient temp. (°C)	-40	-40	-40
Less hotspot allowance (K)	-10	-10	-15
Equals max. permissible temp.rise (K)	80	105	125
Less max. design temp. rise (K)	-80	-80	-80
Equals min. safety margin (K)	-	25	45

The DBAH version will provide a safety margin of 45K and can be safely operated at elevated ambient temperatures. Due to their conservative design many sizes in the DBA range of motors have temperature rises considerably less than 80K and therefore provide even greater safety margins.

Thermal protection

Motors can be protected against excessive temperature rise by inserting, at various positions within the windings, thermal probes which can either give a warning signal or cut off the supply to the motor in the event of a temperature abnormality.

The units fitted to DBA motors, frame sizes 160 and above, are PTC thermistors. These thermovisible resistors, with positive temperature co-efficient, are fitted one per phase, series connected and are terminated in a terminal strip located in the terminal box. Trip temperature is 160°C (180°C for DBAH series). Additional 130°C thermistors can be fitted as an option for alarm connection.

Paint / Finishing

Type	Colour	Code
DBA1	Blue	RAL5010
DBA2	Grey	RAL7012
DBA3	Green	RAL6032
DBAM	Green	RAL6032

* The Final Top coat for CMP Motors is enamel paint. Epoxy paint is also available upon request.

DBA1 Series Motor Bearings

As standard, frame sizes 71 to 180 have high quality deep groove ball bearings with full contact seals. Bearings are prepacked with grease which, under normal operating conditions, provide a high degree of operational reliability. Frame sizes 200 to 355 have high quality bearings with facilities to enable replenishment of the lubricant during operation. Grease nipples are fitted to endshields with the grease relief chute blanked off by a removable plate.

The table below sets out the permissible forces that can be applied to the motor shaft. Values assume the occurrence of only radial or axial loading. Point of application of the force is assumed to be at the tip of the shaft. Rotor weights have already been allowed for in the calculation of radial and axial loads. These loads are applicable for horizontal mounting only. The values are calculated on the basis of basic rating life or fatigue life L_{10} of 40,000 hours. Adjusted rating life for specific applications can be calculated if all influencing factors are known.

Greater axial forces can be tolerated if the motors are provided with angular contact ball bearings. Note that in such cases, the axial force must operate in one direction.

Lubrication

DBA motors standard bearings are lubricated with lithium based rolling contact bearing grease suitable for operation within the cooling air temperature range of -20°C to $+55^{\circ}\text{C}$. For operation outside this temperature range special lubricants are required. DBAH, DBAS and DBAHS motors use Magnalube G grease.

Special lubricants or additional maintenance may be required in the case of motors exposed to comparatively high degrees of pollution, high humidity, increased or changed bearings loads, or prolonged continuous operation.

Permissible radial and axial forces – standard B3 mounted motors

Motor frame	Bearing		Permissible radial force [N]				Permissible axial force [N]			
	D-end	N-end	2 pole	4 pole	6 pole	8 pole	2 pole	4 pole	6 pole	8 pole
71	6202-C3	6202-C3	320	380	-	-	235	320	-	-
80	6204-C3	6204-C3	465	595	685	-	395	540	650	-
90	6205-C3	6205-C3	490	620	720	-	415	570	685	-
100	6206-C3	6206-C3	700	885	1030	1140	570	775	940	1075
112	6206-C3	6206-C3	960	1230	1415	1575	785	1080	1305	1515
132	6308-C3	6308-C3	1410	1815	2095	2320	1160	1590	1910	2200
160	6309-C3	6309-C3	1825	2345	2710	3020	1470	2030	2450	2800
180	6311-C3	6311-C3	2495	3200	3765	4200	1985	2700	3265	3755
200	6312-C3	6312-C3	2905	3745	4345	4825	2220	3055	3705	4225
225-2	6312-C3	6312-C3	2905	3745	4345	4825	2220	3055	3705	4225
225-4,6,8	6313-C3	6313-C3	3265	4010	4725	5205	2460	3385	4120	4730
250-2	6313-C3	6313-C3	3265	4010	4725	5205	2460	3385	4120	4730
250-4,6,8	6314-C3	6314-C3	3570	4635	5370	5960	2730	3775	4560	5220
280-2	6314-C3	6314-C3	3455				2605			
280-4,6,8	6317-C3	6317-C3		8170	9360	10270		4560	5580	6365
315-2	6317+C3	6317-C3	3550				2730			
315-4,6,8	NU319-C3	6319-C3		15720	17925	19660		4835	5890	6770
355-2	6319-C3	6319-C3	3760				2875			
355-4,6,8	NU322-C3	6322-C3		22125	25350	27860		6115	7390	8530

Recommended Grease Replenishment Intervals (Hours) ¹⁾

Bearing number ²⁾	Bearing bore [mm]	Qty of grease [g]	3000 r/min		1500 r/min		1000 r/min		750 r/min	
			Ball	Roller	Ball	Roller	Ball	Roller	Ball	Roller
6312/NU312	60	20	3800	1900	10100	5050	16000	8000	20000	10800
6313/NU313	65	25	3400	1700	9400	4700	15100	7500	20000	10300
6314/NU314	70	30	3000	1500	8800	4400	14300	7150	19500	9750
6315/NU315	75	30	2570	1285	8200	4100	13500	6750	18500	9250
6316/NU316	80	35	2200	1100	7600	3800	12800	6400	17700	8850
6317/NU317	85	40	1800	900	7100	3550	12100	6050	16800	8400
6318/NU318	90	45	1650	825	6600	3300	11500	5750	16000	8000
6319/NU319	95	45	1500	750	5700	2850	9000	4500	14600	7300
6322/NU322	110	60	1200	600	4800	2400	8300	4150	13400	6700

¹⁾ Based on maximum grease service life of 20,000 hours

²⁾ Refer to Nameplate / Motor to confirm Bearing size.

High capacity bearings

For frame sizes 200 to 280 in applications with increased radial force, cylindrical roller bearings can be substituted for ball bearings at the drive end, according to the accompanying table. When a roller bearing is fitted to the D-end, the N-end ball bearing is locked with a circlip to prevent axial movement. Note that the use of roller bearings is not recommended for 2 pole motors.

Permissible radial force - high capacity

Motor frame	D-end Roller	N-end Ball	Permissible radial force [N]		
			4 pole	6 pole	8 pole
200	NU312	6312	5825	6730	7455
225	NU313	6313	6015	7055	7740
250	NU314	6314	7295	8420	9315
280	NU317	6317	13445	15320	16770

* DBA D-end bearing = NU6315

Motor Terminal Box and Cable Entry

- Standard terminal box is mounted on the Top. Motors are also available with on the right hand

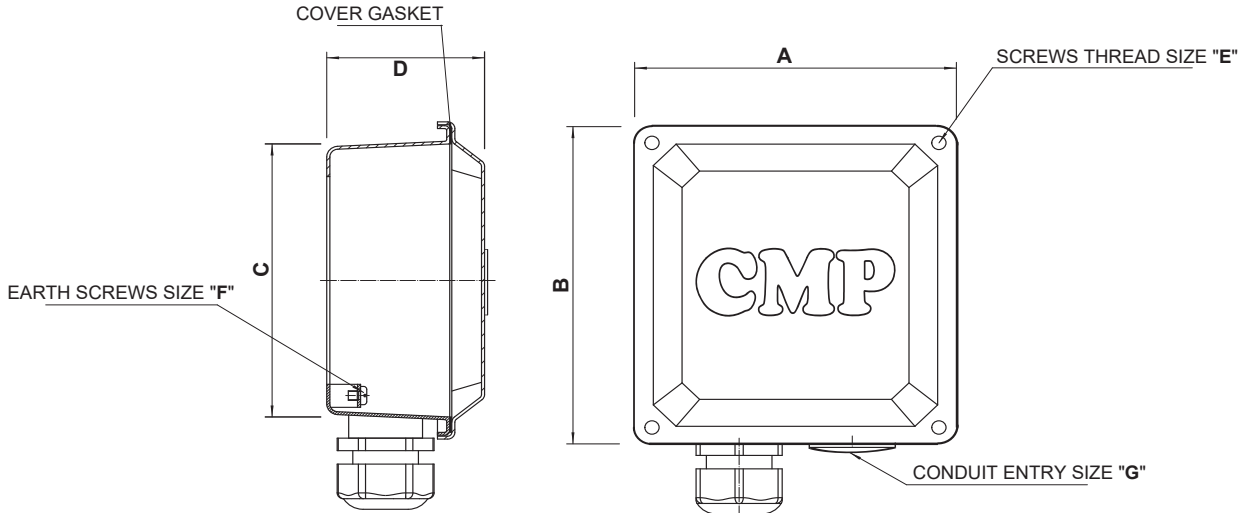

Frame Size	A	B	C	D	E	F	G
71-80	103	103	84	51	M5	M5	1-M20x1.5
90-100	109	109	92	53	M5	M5	1-M20x1.5
112-132	118	126	108	65	M5	M5	2-M25x1.5
160	158	165	145	78	M6	M6	2-M25x1.5
180	158	165	145	78	M6	M6	2-M32x1.5
200	197	213	191	100	M6	M6	2-M32x1.5
225	197	213	191	100	M6	M6	2-M40x1.5
250	224	248	218	115	M8	M8	2-M40x1.5
280	224	248	218	115	M8	M8	2-M50x1.5
315	310	342	305	162	M10	M10	2-M63x1.5
355	362	400	355	172	M12	M10	2-M63x1.5

Vibration, balancing and noise

Vibration

DBA motors fall within the limits of vibration severity set out in standard IEC 60034-14 which are listed below. As specified in the standard, these values relate to rotating machinery measured in soft suspension.

Vibration severity limit, Level N

Motor frame	Maximum RMS vibration velocity [mm/s]
71	1.6
80	1.6
90	1.6
100	1.6
112	1.6
132	1.6
160	2.2
180	2.2
200	2.2
225	2.2
250	2.2
280	2.2
315	2.8
355	2.8

Balancing

Rotors have been dynamically balanced with a half key. Pulleys or couplings used with motors must also be appropriately balanced.

Name Plate Design



 	CMP ELECTRIC MOTOR (AUSTRALIA) PTY LTD						
	PREMIUM EFFICIENCY MOTOR						
SER. NO.				IM	INS.CL		
TYPE				IP	DUTY		
VOLTS	Hz	KW	AMPS	COSφ	R.P.M	EFF 100%/75%/50%	
PRO.NO.	AMB.TEMP.			°C	KG		
BEARING					YOM		

Electrical Specifications

As standard, DBA motors have the following design and operating parameters. Performance data is based on this standard. Any deviation should be examined and performance values altered in accordance with the information provided in this section.

- Three phase, 415V, 50Hz
- Ambient cooling air temperature, 40°C
- Altitude - 1000m
- Duty cycle - S1 (continuous)
- Rotation - Clockwise viewed from drive end
- Connection - 240 volt Delta/415 volt Star (3kW and below)
- 415 volt Delta/720 volt Star (4kW and above)

Motor wound for 50Hz at rated voltage -	Connected to	Data in percentage of values at 50Hz and rated voltage						
		Output	r/min	I _N	I _L /I _N	T _N	T _L /T _N	T _B /T _N
380V	400V 50Hz	100	100	95	110	100	110	110
	380V 60Hz	100	120	98	83	83	70	85
	400V 60Hz	105	120	98	90	87	80	90
	415V 60Hz	110	120	98	95	91	85	93
	440V 60Hz	115	120	100	100	96	95	98
	460V 60Hz	120	120	100	105	100	100	103
400V	380V 50Hz	100	100	105	91	100	90	90
	415V 50Hz	100	100	96	108	100	108	108
	400V 60Hz	100	120	98	83	83	70	85
	415V 60Hz	104	120	98	89	86	75	88
	440V 60Hz	110	120	98	95	91	85	93
	460V 60Hz	115	120	100	100	96	93	98
415V	480V 60Hz	120	120	100	105	100	100	103
	380V 50Hz*	100	100	109	84	100	84	84
	400V 50Hz	100	100	104	93	100	93	93
	440V 50Hz	100	100	94	112	100	112	112
	415V 60Hz	100	120	98	83	83	70	85
	440V 60Hz	105	120	98	90	87	80	90
460V 60Hz	110	120	98	95	91	85	94	
	480V 60Hz	115	120	100	100	96	95	98

Duty Cycles

S1 Continuous Duty	Operation under constant load, lasting long enough to allow the machine to reach thermal equilibrium
S2 Short-Time Duty	Operation under constant load, for a time to start to allow the machine to reach terminal equilibrium. Idle time of the machines is long enough to allow the machine to cool down to ambient temperature. Standard duration of short-time operation : 10, 30, 60 and 90 minutes
S3 Intermittent Periodic Duty	Operation under repeated, constant load in specific cycles. Neither operating nor resting period are long enough to allow the motor reach thermal equilibrium. The starting losses are small and do not essentially influence the temperature rise. The nominal values of relative starting time are 15, 25, 40, 60% at a daily 10-minute cycle.
S4 Intermittent periodic Duty	Operation under repeated, constant load in specified cycles. The start of the motor influences the temperature rise.
S5 Intermittent Periodic Duty	Same as S4 Operation, except that the electric braking of the machine had an essential influence on the temperature rise
S6 Continuously Operation with Cyclic Load	Operation consisting of a continuous series of equal cycles. Each cycle is made up of no-load and a constant load period. The cycle duration is not long enough to allow the machine to reach thermal equilibrium in one cycle. In order to define S6 operation, the relative starting time must be specified.
S7 Intermittent Periodic Duty with Starting and Braking	Uninterrupted operation with a series of constant loading and braking periods. The most demanding type of operation for the motor. In order to define this type of operation, the number of cycles per hour and the inertia constant must be specified.

* Not applicable for motors with F class temperature rise.
Note: This table is not applicable for hazardous area motors.

- 1) I_N = Full load current T_N = Full load torque
- I_L/I_N = Locked rotor current/ full load current T_L/T_N = Locked rotor torque/ full load torque
- T_B/T_N = Breakdown torque/full load torque

Standard torque values for alternative supplies are obtainable only with special windings. For these purpose-built motors the performance data is the same as for 415V motors except for the currents which are calculated with the accompanying formula:

$$I_x = \frac{415 \times I_N}{U_x}$$

Where:

- I_x = Current
- I_N = Full load current at 415 volt
- U_x = Design voltage

IP protection

Protection of persons against getting in contact with (or approaching) live parts and against contact with moving parts inside the enclosure. Also protection of the machine against ingress of solid foreign objects. Protection of machines against the harmful effects due to the ingress of water.

Explanation of the IP code

Ingress protection	Degree of protection to persons and to parts of the motors inside the enclosure	Degree of protection provided by the enclosure with respect to harmful effects due to ingress of water
IP	5	5
	Position 1	Position 2

Position 1

- 2: Motors protected against solid objects greater than 12 mm
- 4: Motors protected against solid objects greater than 1 mm
- 5: Dust-protected motors
- 6: Dust-tight motors

Position 2

- 3: Motors protected against spraying water
- 4: Motors protected against splashing water
- 5: Motors protected against water jets
- 6: Motors protected against heavy seas

Temperature and Altitude

The performance data are based at standard ambient conditions of 40°C at 1000 meter above sea level. For any conditions differ from this standard, please contact CMP for the parameter factoring.

Connections / Diagrams

For Single Speed Motor at and below 3.0KW, the standard connections are 230V Delta/400V Star (for 400V Winding). Designed for 400V Direct on Line (DOL) starting, at star terminal connection.

For Single Speed Motor at and above 4.0KW, the standard connections are 400V Delta/690V Star (for 400V winding). These connection are suitable for various starting methods mentioned below.

Connection for single speed motors:

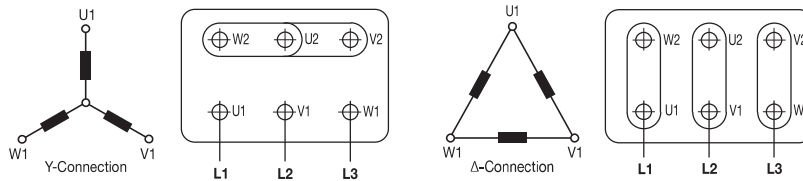

Two separate windings for two speed motors:

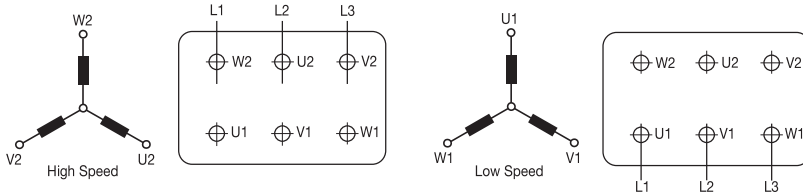

Dahlander system for two speed motors:

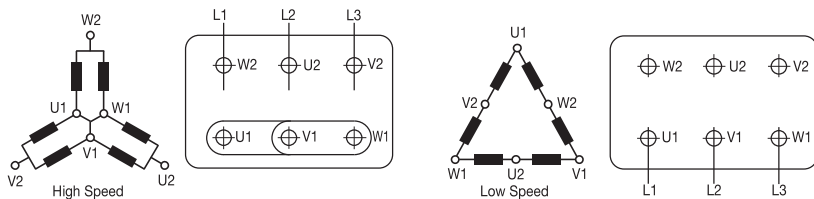

Starting Methods

All of the following starter options are available through CMP Drives division, and are best supplied together with the motor.

D.O.L. Starters

When an electric motor is started by direct connection o the power supply (D.O.L.), it draws a high current, called the 'starting current', which is approximately equal in magnitude to the locked rotor current I_L . As listed in the performance data, locked rotor current can be up to 8 times the rated current I_N of the motor. In circumstances where the motor starts under no load or where high starting toque is not required, it is preferable to reduce the starting current by one of the following means.

Star - Delta starting

DBA motors 4.0kW and above are suitable for the star-delta starting method. Through the use of a star-delta starter, the motor terminals are connected in the star configuration during starting, and reconnected to the delta configuration when running. The benefits of this starting method are a significantly lower starting current, to a value about 1/3 of the D.O.L. starting current, and a corresponding starting torque also reduced to about 1/3 of its D.O.L. value. It should be noted that a second current surge occurs on changeover to the delta connection. The level of this surge will depend on the speed the motor has reached at the moment of changeover.

Electronic soft starters

Through the use of an electronic soft starter, which controls such parameters as current and voltage, the starting sequence can be totally controlled. The starter can be programmed to limit the amount of starting current. By limiting the rate of the current increase the startup time is extended. This starting method is particularly suitable for centrifugal loads (fans and pumps).

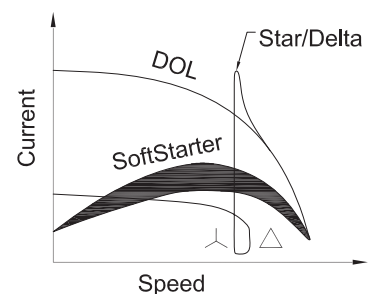

Number of starts per hour

The number of starts per hour is dependant on the inertia of the driven load and the load torque demand. When high inertia load is applied (flywheel, heavy fan etc) please refer to your nearest CMP office for advice. A guide to generally acceptable starts per hour would be as per table.

For greater number of starts per hour, please contact your nearest CMP office for advice.

Frame	Starts per Hour			
	2 Pole	4 Pole	6 Pole	8 Pole
71 *	-	40	-	-
80 *	20	40	40	-
90	16	30	40	-
100	16	30	40	40
112	16	30	40	40
132	10	20	25	25
160	10	20	25	25
180	8	15	20	20
200	6	12	12	12
225	5	10	10	10
250	4	8	8	8
280	3	6	6	6
315	3	4	4	4

* 20 Starts / Hour for Ex tD brake Motors

Permitted starting time

In respect to the temperature rise of the motor, starting time (i.e., from rest to operational speed) should not exceed the time indicated in the following table. Motor must be allowed to cool prior to each start.

Note: For Ex e motors t_E time stated on motor name plate takes precedence over these times

Frame	Starting method	Maximum starting time [sec]			
		2 pole	4 pole	6 pole	8 pole
71	D.O.L.	-	26	-	-
80	D.O.L.	15	26	40	-
90	D.O.L.	10	15	25	-
100	D.O.L.	12	13	18	40
112	D.O.L.	10	10	18	35
132	D.O.L.	14	12	12	25
160-355	D.O.L.	15	15	20	20
160-355	Star-delta	45	45	60	60

Mounting Arrangements

Foot Mounting Horizontal

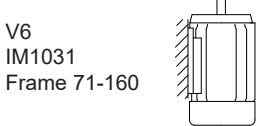
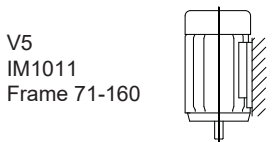
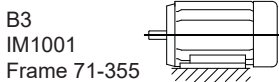

Foot Mounting Vertical

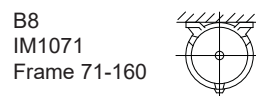
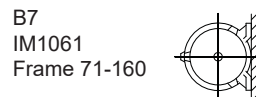
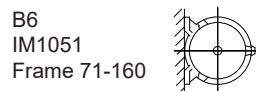

Flange Mounting

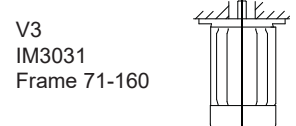
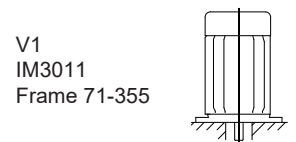
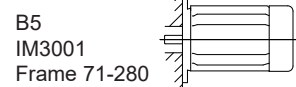

Foot & Flange Mounting

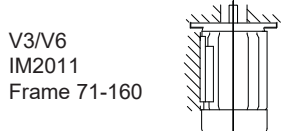
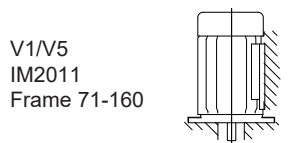
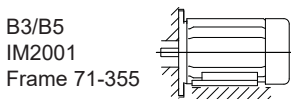

Face Mounting

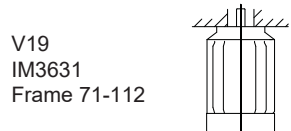
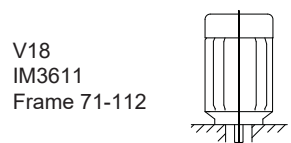
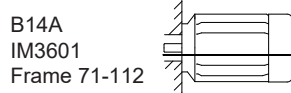

Foot & Face Mounting

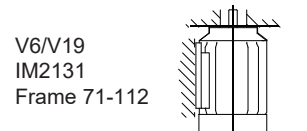
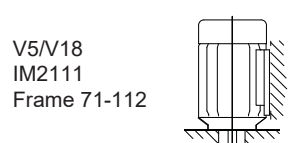
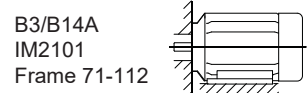

Standards

All electric motors featured in this catalogue meet the relevant IEC, EN, ISO, DIN and NEN standards. The most important standards are listed in the table below.

Description	EN-IEC	ISO	DIN
Nominal operation and properties	IEC 60034-1		
Degree of protection	IEC 60034-5		DIN 40050
Cooling method	IEC 60034-6		
Mountings	IEC 60034-7		
Direction of rotation & connection terminals marking	IEC 60034-8		
Noise	IEC 60034-9		
Voltage	IEC 60038		
Dimensions & tolerances	EN 50347		
Balancing		ISO 2373	DIN 45665
Energy Efficiency	IEC 60034-30		

ErP Directive 2009/125/EC

Implementations Dates

- 16 Jun 2011: IE2 minimum efficiency for motors from 0.75 kW – 375 kW
(IE2 motors can be used with frequency inverters)
- 01 Jan 2015: IE3 minimum efficiency for motors from 7.5 kW – 375 kW
- 01 Jan 2017: IE3 minimum efficiency for motors from 0.75 kW – 375 kW
(IE3 motors can be used with frequency inverters)

ErP Regulation does not apply to:

(a) motors operating wholly immersed in a liquid (b) motors completely integrated into a product (c) motors specifically designed to operate:

- (i) at altitudes exceeding 1000 metres a.s.l.
(soon to be changed to 4000 metres a.s.l.)
- (ii) where ambient temperatures exceed 40°C
(soon to be changed to outside of -30°C to +60°C)
- (iii) in maximum operating temperature > 400°C
- (iv) where ambient temperatures < -15°C (any motor)
or < 0°C for a motor with air cooling
- (v) where water coolant temperature < 5°C or > 25°C
- (vi) in potentially explosive atmospheres
- (d) brake motors
- (e) motors made solely for converter operation

ErP Regulation applies to:

- Single speed, three-phase 50Hz or 50/60Hz induction motors - have 2 to 6 poles
- have a rated voltage of Un up to 1000 V
- have a rated output Pn between 0.75 kW and 375 kW
- are rated on the basis of S1 continuous duty operation

EFFICIENCY

HIGH	IE4* Supper Premium Efficiency	
	IE3 Premium Efficiency	NEMA Premium EISA 2007 from Dec 2010
	IE2 High Efficiency	NEMA Energy Efficient EPAct
	IE1 Standard Efficiency	
LOW		
	IEC Motors	NEMA Motors

*IE4 is under development

Electric motor parts

ELECTRIC MOTOR PART

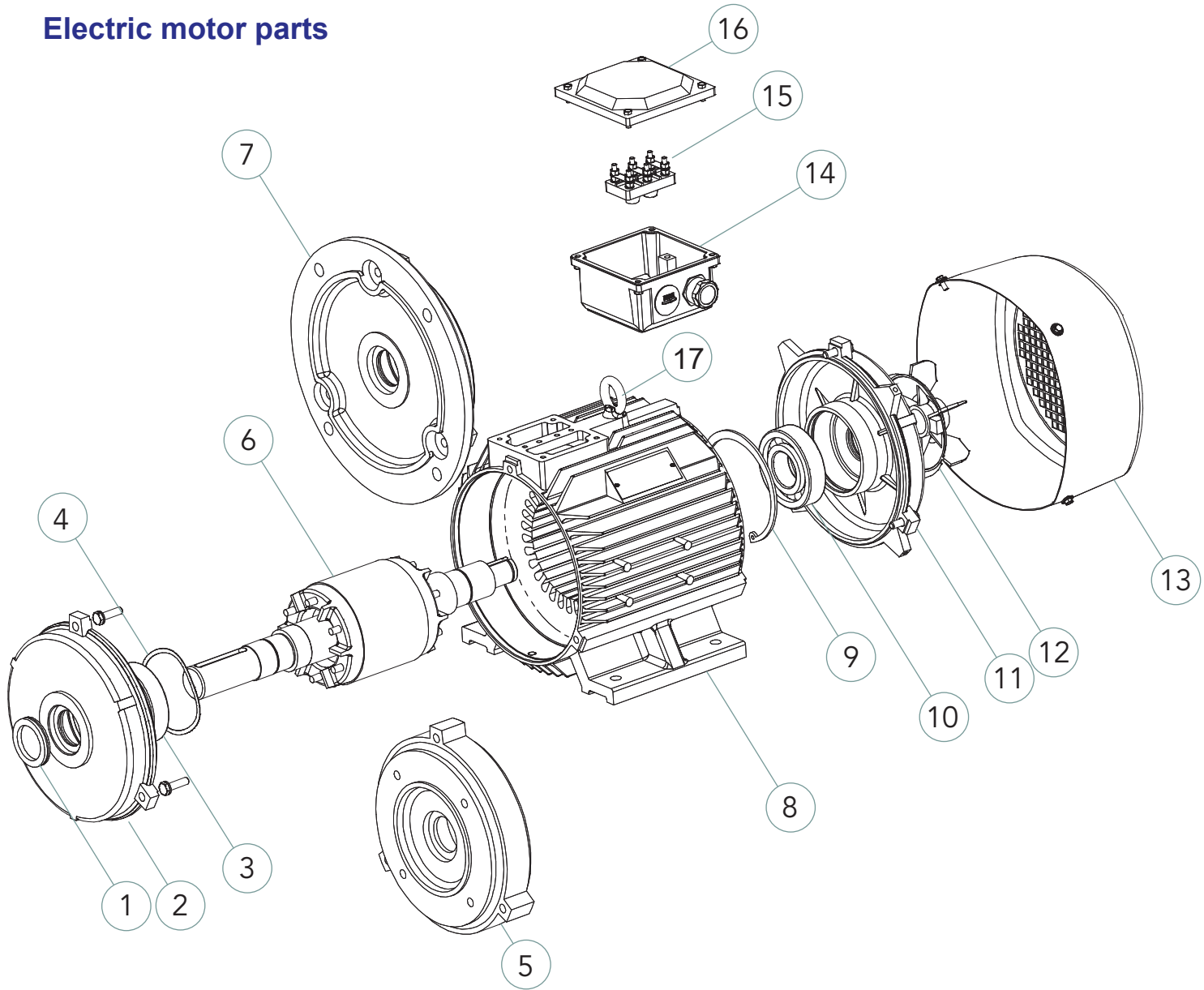

- 1 - Shaft seal
- 2 - DE Endshield
- 3 - DE Bearing
- 4 - Wavy washer
- 5 - Flange (B14A)
- 6 - Rotor with shaft
- 7 - Flange (B5)
- 8 - Stator housing with stator inside
- 9 - Circlip for fixing the bearing at NDE
- 10 - NDE Bearing
- 11 - NDE Endshield
- 12 - Cooling fan
- 13 - Fan cover
- 14 - Terminal box
- 15 - Terminal block with 6 pins and connection links
- 16 - Terminal box lid
- 17 - Lifting eye

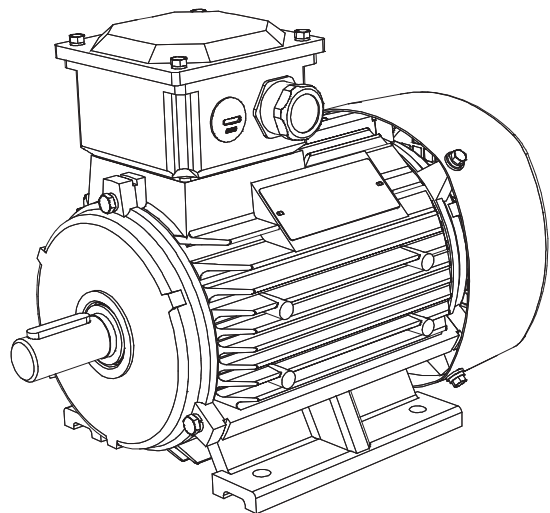

Performance Data 400V/3Ph/50Hz

Class F, IP55 Class B Temperature Rise

KW	Motor Frame Size	Shaft (mm)	Speed (RPM)	Current		Efficiency %			Power Factor (cosφ)			Torque			Moment of inertia J=¼GD² (kg m²)	Weight of foot mount motor (Kgs)
				Full load (A)	Locked Rotor Ist/IN	100	75	50	100	75	50	Full Load (Nm)	Locked Rotor Tst/TN	Break Down Tmax/TN		
3000 RPM = 2Poles																
0.75	80M1	19	2845	1.8	6.1	72.1	71.8	68.7	0.83	0.77	0.65	2.5	2.2	2.3	0.0008	12
1.1	80M2	19	2840	2.5	7	75.0	75.4	73.1	0.84	0.79	0.68	3.7	2.2	2.3	0.0010	14
1.5	90S	24	2840	3.3	7	77.2	77.5	75.7	0.84	0.81	0.71	5	2.2	2.3	0.0015	18
2.2	90L	24	2840	4.7	7	79.7	80.2	78.6	0.85	0.82	0.73	7.4	2.2	2.3	0.0021	24
3	100L	28	2860	6.1	7.5	81.5	81.9	80.3	0.87	0.84	0.75	10	2.2	2.3	0.0031	30
4	112M	28	2880	7.9	7.5	83.1	83.8	83.1	0.88	0.87	0.79	13.3	2.2	2.3	0.0058	36
5.5	132S1	38	2900	10.7	7.5	84.7	84.6	83.0	0.88	0.85	0.77	18.1	2.2	2.3	0.0113	56
7.5	132S2	38	2900	14.3	7.5	86.0	86.4	85.5	0.88	0.88	0.81	24.7	2.2	2.3	0.0133	60
11	160M1	42	2930	20.4	7.5	87.6	87.1	85.1	0.89	0.87	0.80	35.9	2.2	2.3	0.0443	102
15	160M2	42	2930	27.4	7.5	88.7	88.5	87.0	0.89	0.88	0.82	48.9	2.2	2.3	0.0549	114
18.5	160L	42	2930	33.2	7.5	89.3	89.2	87.9	0.90	0.89	0.83	60.3	2.2	2.3	0.0620	128
22	180M	48	2940	39.2	7.5	89.9	89.5	87.7	0.90	0.89	0.82	71.5	2.0	2.3	0.0853	173
30	200L1	55	2950	53.6	7.5	90.7	90.4	88.9	0.89	0.89	0.83	97.1	2.0	2.3	0.153	230
37	200L2	55	2950	65.1	7.5	91.2	91.1	89.9	0.90	0.90	0.84	119.8	2.0	2.3	0.178	244
45	225M	55	2960	78.7	7.5	91.7	91.4	90.1	0.90	0.89	0.83	145.2	2.0	2.3	0.277	286
55	250M	60	2965	95.8	7.5	92.1	91.6	90.0	0.90	0.88	0.81	177.2	2.0	2.3	0.388	377
75	280S	65	2970	129.8	7.5	92.7	92.2	90.7	0.90	0.90	0.84	241.2	2.0	2.3	0.574	490
90	280M	65	2970	153.5	7.5	93.0	92.7	91.4	0.91	0.91	0.86	289.4	2.0	2.3	0.677	539
110	315S	65	2980	187	7.1	93.3	92.5	90.5	0.91	0.89	0.84	352.5	1.8	2.2	1.40	846
132	315M	65	2980	223.9	7.1	93.5	92.8	91.1	0.91	0.90	0.86	423	1.8	2.2	1.57	942
160	315L1	65	2980	267.6	7.1	93.8	93.2	91.5	0.92	0.91	0.87	512.8	1.8	2.2	1.76	1014
185	315L	65	2980	306.9	7.1	93.8	93.2	91.6	0.92	0.90	0.86	592.9	1.8	2.2	2.050	1014
200	315L2	65	2980	333.8	7.1	94.0	93.6	92.3	0.92	0.91	0.88	640.9	1.8	2.2	2.35	1136
220	355M1	75	2980	364.1	7.1	94.0	93.6	92.5	0.92	0.92	0.89	705	1.8	2.2	2.75	1168
250	355M2	75	2980	417.3	7.1	94.0	93.5	92.2	0.92	0.92	0.90	801.2	1.6	2.2	3.25	1785
315	355L2	75	2980	525.8	7.1	94.0	93.6	92.4	0.92	0.93	0.91	1009.5	1.6	2.2	3.93	1806
High Output Frame																
5.5	112M2	28	2900	10.7	7.5	84.7	87.1	86.5	0.88	0.89	0.82	18.1	2.2	2.3	0.0113	45
11	132M	38	2930	20.4	7.5	87.6	89.3	88.5	0.89	0.89	0.83	35.9	2.2	2.3	0.0443	69
75	250M2	60	2965	129.8	7.5	92.7	93.1	91.6	0.90	0.90	0.85	241.2	2	2.3	0.574	440
110	280M2	65	2980	187	7.1	93.3	93.2	91.3	0.91	0.89	0.84	353	1.8	2.2	1.400	868

* Data are for reference only

Data at various voltages

KW	Motor Frame Size	Shaft (mm)	Speed	Full Load Current @ 50Hz			Speed	Full Load Current @ 60Hz			Noise Level No Load @ 1 Metre dB(A)
			50Hz (RPM)	380V (A)	400V (A)	415V (A)	60Hz (RPM)	440V (A)	460V (A)	480V (A)	
3000 RPM = 2Poles											
0.75	80M1	19	2845	1.9	1.8	1.8	3404	1.7	1.7	1.6	67
1.10	80M2	19	2840	2.6	2.5	2.5	3404	2.5	2.4	2.4	67
1.50	90S	24	2840	3.4	3.3	3.3	3404	3.2	3.2	3.1	72
2.2	90L	24	2840	4.8	4.7	4.6	3404	4.7	4.6	4.5	72
3	100L	28	2860	6.3	6.1	6	3428	6	5.9	5.7	76
4	112M	28	2880	8.1	7.8	7.8	3452	7.9	7.7	7.6	77
5.5	132S1	38	2900	11	10.7	10.5	3476	10.6	10.4	10.2	80
7.5	132S2	38	2900	14.7	14.3	14.1	3476	14.3	13.9	13.7	80
11	160M1	42	2930	21.0	20.4	20.1	3512	20.8	20.4	20	86
15	160M2	42	2930	28.2	27.4	27	3512	28	27.4	26.9	86
18.5	160L	42	2930	34.2	33.2	32.8	3512	33.8	33	32.3	86
22	180M	48	2940	40.4	39.2	38.7	3524	40.1	39.2	38.4	89
30	200L1	55	2950	55.2	53.6	52.6	3536	54.9	53.6	52.6	92
37	200L2	55	2950	67.0	65.1	64.1	3536	66	64.6	63.3	92
45	225M	55	2960	81.0	78.7	77.6	3548	80.1	78.3	76.8	92
55	250M	60	2965	98.6	95.8	94.4	3554	97.2	95	93.1	93
75	280S	65	2970	133.0	129.8	127.9	3560	131.6	128.7	126.1	94
90	280M	65	2970	158.1	153.5	151.3	3560	156.2	152.7	149.6	94
110	315S	65	2980	192.6	187.0	184.3	3566	190.9	186.6	182.8	96
132	315M	65	2980	230.6	223.9	220.7	3566	226.4	221.3	216.8	96
160	315L1	65	2980	275.7	267.6	263.7	3566	271.5	265.3	259.9	99
185	315L	65	2980	318.1	308.8	304.2	3566	313.6	306.4	300.1	99
200	315L2	65	2980	343.9	333.8	328.9	3566	339.4	331.7	324.9	99
220	355M1	75	2980	378.3	367.1	361.8	3566	373.3	364.8	357.3	103
250	355M2	75	2980	429.9	417.3	411.1	3572	424.2	414.6	406.1	103
315	355L2	75	2980	541.7	525.8	518	3572	534.6	522.4	511.7	103
High Output Design											
5.5	112M2	28	2900	11.3	10.7	10.1	3480	9.6	9.2	8.8	80
11	132M	38	2930	21.5	20.4	19.7	3516	17.7	16.9	16.2	86
75	250M2	60	2970	136.6	129.8	125.1	3564	116.8	111.7	107.1	94
110	280M2	65	2970	196.8	187	180.2	3564	168.7	161.4	154.7	96

* Data are for reference only

Performance Data 400V/3Ph/50Hz Class

F, IP55 Class B Temperature Rise

KW	Motor Frame Size	Shaft (mm)	Speed (RPM)	Current		Efficiency %			Power Factor (cosφ)			Torque			Moment of inertia J=1/4GD ² (kg m ²)	Weight of foot mount motor (Kgs)
				Full load (A)	Locked Rotor Ist/IN	100	75	50	100	75	50	Full Load (Nm)	Locked Rotor Tst/TN	Break Down Tmax/TN		
1500 RPM = 4Poles																
0.37	71M2	14	1340	1.1	5	67.0	68.2	67.5	0.75	0.67	0.54	2.6	2.0	2.2	0.0009	11
0.55	80M1	19	1390	1.5	5.2	71.0	71.8	68.0	0.76	0.66	0.53	3.8	2.4	2.3	0.0013	14
0.75	80M2	19	1380	2	6	72.1	72.8	71.9	0.76	0.69	0.55	5.2	2.3	2.3	0.0017	16
1.10	90S	24	1390	2.7	6	75.0	76.3	74.3	0.77	0.72	0.59	7.6	2.3	2.3	0.0026	18
1.50	90L	24	1390	3.6	6	77.2	78.4	77.9	0.79	0.73	0.60	10.3	2.3	2.3	0.0035	22
2.2	100L1	28	1410	4.9	7	79.7	80.5	80.0	0.81	0.75	0.62	14.9	2.3	2.3	0.0065	30
3	100L2	28	1410	6.5	7	81.5	82.5	82.2	0.82	0.77	0.65	20.3	2.3	2.3	0.0088	32
4	112M	28	1435	8.5	7	83.1	83.9	85.0	0.82	0.77	0.65	26.6	2.3	2.3	0.0098	42
5.5	132S	38	1440	11.3	7	84.7	85.3	86.3	0.83	0.79	0.68	36.5	2.3	2.3	0.0254	56
7.5	132M	38	1440	15	7	86.0	86.6	87.6	0.84	0.80	0.70	49.7	2.3	2.3	0.0351	70
11	160M	42	1460	21.6	7	87.6	87.8	88.5	0.84	0.80	0.70	72	2.2	2.3	0.0798	106
15	160L	42	1460	28.7	7.5	88.7	88.9	89.6	0.85	0.80	0.71	98.1	2.2	2.3	0.106	130
18.5	180M	48	1470	34.8	7.5	89.3	89.5	90.4	0.86	0.81	0.71	120.2	2.2	2.3	0.147	162
22	180L	48	1470	41.1	7.5	89.9	90.2	90.9	0.86	0.81	0.71	142.9	2.2	2.3	0.164	176
30	200L	55	1470	55.5	7.2	90.7	90.8	91.5	0.86	0.83	0.73	194.9	2.2	2.3	0.268	230
37	225S	60	1475	67.3	7.2	91.2	91.2	91.8	0.87	0.84	0.77	239.6	2.2	2.3	0.458	278
45	225M	60	1475	81.4	7.2	91.7	91.7	92.4	0.87	0.84	0.76	291.4	2.2	2.3	0.56	309
55	250M	65	1480	99.1	7.2	92.1	92.0	92.3	0.87	0.84	0.76	354.9	2.2	2.3	0.773	412
75	280S	75	1480	134.2	7.2	92.7	92.6	92.5	0.87	0.86	0.79	484	2.2	2.3	1.23	501
90	280M	75	1480	160.6	7.2	93.0	92.7	92.9	0.87	0.84	0.76	580.7	2.2	2.3	1.54	576
110	315S	80	1480	193.4	6.9	93.3	92.9	93.1	0.88	0.86	0.79	709.8	2.1	2.2	2.97	889
132	315M	80	1480	231.6	6.9	93.5	93.2	93.6	0.88	0.86	0.80	851.8	2.1	2.2	3.34	982
160	315L1	80	1480	276.6	6.9	93.8	93.5	93.6	0.89	0.87	0.82	1032.4	2.1	2.2	4.03	1070
185	315L	80	1480	319.9	6.9	93.8	93.5	93.4	0.89	0.85	0.77	1193.7	2.1	2.2	4.46	1152
200	315L2	80	1480	345.1	6.9	94.0	93.9	93.9	0.89	0.88	0.83	1290.5	2.1	2.2	4.88	1174
220	355M1	95	1480	376	6.9	94.0	94.0	93.8	0.89	0.88	0.83	1419.6	2.1	2.2	6.45	1423
250	355M2	95	1490	426.5	6.9	94.0	93.7	94.2	0.90	0.90	0.86	1602.4	2.1	2.2	8.33	1638
280	355L1	95	1490	477.7	6.9	94.0	93.9	94.6	0.90	0.91	0.88	1794.7	2.1	2.2	9.42	1735
315	355L2	95	1490	537.4	6.9	94.0	93.8	94.7	0.90	0.91	0.87	2019	2.1	2.2	10.51	1832
High Output Frame																
5.5	112M2	28	1440	11.3	7	84.7	85.3	84.4	0.83	0.78	0.67	36.5	2.3	2.3	0.0254	48
11	132M2	38	1460	21.6	7	87.6	87.8	86.7	0.84	0.82	0.73	72	2.3	2.3	0.0798	78
75	250M2	65	1480	134.2	7.2	92.7	92.6	91.5	0.87	0.87	0.82	484	2	2.3	1.230	450
110	280M2	75	1480	193.4	6.9	93.3	92.9	91.7	0.88	0.86	0.79	709.8	1.8	2.2	2.970	656

* Data are for reference only

Data at various voltages

KW	Motor Frame Size	Shaft (mm)	Speed	Full Load Current @ 50Hz			Speed	Full Load Current @ 60Hz			Noise Level No Load @ 1 Metre dB(A)
			50Hz (RPM)	380V (A)	400V (A)	415V (A)	60Hz (RPM)	440V (A)	460V (A)	480V (A)	
1500 RPM = 4Poles											
0.37	71M2	14	1340	1.12	1.1	1	1608	1	0.9	0.9	55
0.55	80M1	19	1390	1.6	1.5	1.4	1668	1.4	1.3	1.2	58
0.75	80M2	19	1380	2	2	2	1664	1.8	1.8	1.8	58
1.10	90S	24	1390	2.8	2.7	2.7	1664	2.7	2.6	2.6	61
1.50	90L	24	1390	3.6	3.6	3.5	1664	3.4	3.4	3.3	61
2.2	100L1	28	1410	5.1	4.9	4.9	1688	4.8	4.7	4.6	64
3	100L2	28	1410	6.7	6.5	6.4	1688	6.3	6.2	6.1	64
4	112M	28	1435	8.7	8.5	8.4	1718	8.4	8.2	8.1	65
5.5	132S	38	1440	11.6	11.3	11.2	1724	11.2	10.9	10.7	71
7.5	132M	38	1440	15.4	15.0	14.8	1724	15	14.7	14.4	71
11	160M	42	1460	22.2	21.6	21.3	1748	21.8	21.3	20.9	75
15	160L	42	1460	29.5	28.7	28.3	1748	29	28.4	27.8	75
18.5	180M	48	1470	35.8	34.8	34.3	1760	34.9	34.2	33.5	76
22	180L	48	1470	42.3	41.1	40.5	1760	41.2	40.3	39.6	76
30	200L	55	1470	57.1	55.5	54.8	1760	55.8	54.6	53.6	79
37	225S	60	1475	69.3	67.3	66.4	1766	67.6	66.1	64.9	81
45	225M	60	1475	83.4	81.4	80.3	1766	81.7	79.9	78.4	81
55	250M	65	1480	101.9	99.1	97.7	1772	99.8	97.6	95.8	83
75	280S	75	1480	138.1	134.2	132.4	1772	135.8	132.8	130.3	86
90	280M	75	1480	165.2	160.6	158.4	1772	162.8	159.3	156.2	86
110	315S	80	1480	199	193.4	190.7	1772	196.2	191.9	188.1	93
132	315M	80	1480	238.3	231.6	228.4	1772	232.9	227.8	223.4	93
160	315L1	80	1480	284.8	276.6	272.8	1772	279.2	273.1	267.7	97
185	315L	80	1480	328.6	319.2	314.7	1772	322.5	315.3	309.1	97
200	315L2	80	1480	355.2	345.1	340.2	1772	349	341.3	334.6	97
220	355M1	95	1480	388.7	377.6	372.3	1772	383.9	375.4	368	97
250	355M2	95	1490	449.2	426.5	420.5	1784	431.6	421.9	413.5	101
280	355L1	95	1490	491.9	477.7	470.9	1784	483.4	472.6	463.1	101
315	355L2	95	1490	553.4	537.4	529.8	1784	543.9	531.7	521.1	101
High Output Design											
5.5	112M2	28	1440	11.9	11.3	10.9	1728	10.1	9.7	9.3	71
11	132M2	38	1460	22.7	21.6	20.8	1752	19.4	18.6	17.8	75
75	250M2	65	1480	141.3	134.2	129.3	1776	120.9	115.6	110.8	86
110	280M2	75	1480	203.6	193.4	186.4	1776	173.6	166.0	159.1	93

* Data are for reference only

Performance Data 400V/3Ph/50Hz

Class F, IP55 Class B Temperature Rise

KW	Motor Frame Size	Shaft (mm)	Speed (RPM)	Current		Efficiency %			Power Factor (cosφ)			Torque			Moment of inertia J= $\frac{1}{4}GD^2$ (kg m ²)	Weight of foot mount motor (Kgs)
				Full load (A)	Locked Rotor Ist/IN	100	75	50	100	75	50	Full Load (Nm)	Locked Rotor Tst/TN	Break Down Tmax/TN		
1000 RPM = 6Poles																
0.37	80M1	19	885	1.2	4.7	62.0	62.3	58.0	0.70	0.61	0.48	4	1.9	2.0	0.0017	15
0.55	80M2	19	885	1.7	4.7	65.0	66.2	63.2	0.72	0.63	0.49	5.9	1.9	2.1	0.0022	16
0.75	90S	24	910	2.2	5.5	70.0	70.6	67.2	0.70	0.63	0.50	7.9	2.0	2.1	0.0033	20
1.10	90L	24	910	3	5.5	72.9	74.0	71.6	0.72	0.65	0.51	11.5	2.0	2.1	0.0045	22
1.50	100L	28	920	3.8	5.5	75.2	76.3	74.3	0.75	0.69	0.55	15.6	2.0	2.1	0.0081	28
2.2	112M	28	935	5.4	6.5	77.7	78.9	77.5	0.76	0.69	0.56	22.5	2.0	2.1	0.015	38
3	132S	38	960	7.1	6.5	79.7	79.8	77.7	0.76	0.69	0.56	29.8	2.1	2.1	0.029	58
4	132M1	38	960	9.3	6.5	81.4	81.5	79.7	0.76	0.70	0.57	39.8	2.1	2.1	0.039	68
5.5	132M2	38	960	12.4	6.5	83.1	83.4	82.0	0.77	0.72	0.59	54.7	2.1	2.1	0.053	76
7.5	160M	42	970	16.6	6.5	84.7	84.7	83.0	0.77	0.71	0.59	73.8	2.0	2.1	0.0897	109
11	160L	42	970	23.6	6.5	86.4	86.5	85.2	0.78	0.74	0.62	108.3	2.0	2.1	0.127	134
15	180L	48	970	30.5	7	87.7	88.0	87.0	0.81	0.77	0.66	147.7	2.0	2.1	0.214	176
18.5	200L1	55	980	37.2	7	88.6	88.8	87.9	0.81	0.77	0.66	180.3	2.1	2.1	0.319	216
22	200L2	55	980	42.9	7	89.2	89.6	88.8	0.83	0.79	0.68	214.4	2.1	2.1	0.369	226
30	225M	60	980	57.2	7	90.2	90.3	89.5	0.84	0.81	0.72	292.4	2.0	2.1	0.586	292
37	250M	65	980	68.4	7	90.8	90.9	90.1	0.86	0.83	0.73	360.6	2.1	2.1	0.94	364
45	280S	75	980	82.6	7	91.4	91.4	90.5	0.86	0.82	0.73	438.5	2.1	2.0	1.71	451
55	280M	75	980	100.4	7	91.9	92.0	91.2	0.86	0.83	0.75	536	2.1	2.0	2.150	504
75	315S	80	980	135.9	7	92.6	92.3	91.1	0.86	0.84	0.76	730.9	2.0	2.0	3.45	814
90	315M	80	980	162.6	7	92.9	92.6	91.5	0.86	0.84	0.77	877	2.0	2.0	4.08	928
110	315L1	80	980	197.9	6.7	93.3	93.1	92.0	0.86	0.85	0.78	1071.9	2.0	2.0	5.06	1020
132	315L2	80	980	234.2	6.7	93.5	93.3	92.3	0.87	0.85	0.78	1286.3	2.0	2.0	5.84	1068
160	355M	95	990	279.8	6.7	93.8	93.5	92.4	0.88	0.87	0.81	1543.4	1.9	2.0	9.53	1588
185	355M1	95	990	323.5	6.7	93.8	93.6	92.4	0.88	0.87	0.80	1784.6	1.9	2.0	10.67	1705
200	355M2	95	990	349	6.7	94.0	93.8	92.8	0.88	0.87	0.81	1929.3	1.9	2.0	11.8	1732
220	355L1	95	990	383.9	6.7	94.0	93.7	92.4	0.88	0.87	0.80	2122.2	1.9	2.0	13	1821
250	355L2	95	990	436.2	6.7	94.0	93.8	92.9	0.88	0.88	0.82	2411.6	1.9	2.0	14.8	1884

* Data are for reference only

Data at various voltages

KW	Motor Frame Size	Shaft (mm)	Speed	Full Load Current @ 50Hz			Speed	Full Load Current @ 60Hz			Noise Level No Load @ 1 Metre dB(A)
			50Hz (RPM)	380V (A)	400V (A)	415V (A)	60Hz (RPM)	440V (A)	460V (A)	480V (A)	
1000 RPM = 6Poles											
0.37	80M1	19	885	1.3	1.2	1.2	1062	1.1	1.1	1	54
0.55	80M2	19	885	1.8	1.7	1.6	1062	1.5	1.5	1.4	54
0.75	90S	24	910	2.3	2.2	2.2	1088	2.1	2.0	1.9	57
1.10	90L	24	910	3.1	3.0	3	1088	3	2.9	2.9	57
1.50	100L	28	920	3.9	3.8	3.8	1100	3.8	3.7	3.7	61
2.2	112M	28	935	5.5	5.4	5.3	1118	5.4	5.3	5.2	65
3	132S	38	960	7.3	7.1	7.1	1148	6.9	6.8	6.7	69
4	132M1	38	960	9.6	9.3	9.2	1148	9.2	9	8.9	69
5.5	132M2	38	960	12.7	12.4	12.3	1148	12.3	12.1	11.9	69
7.5	160M	42	970	17.0	16.6	16.4	1160	16.6	16.3	16	73
11	160L	42	970	24.2	23.6	23.3	1160	23.3	22.8	22.4	73
15	180L	48	970	31.3	30.5	30.1	1160	30.4	29.8	29.2	73
18.5	200L1	55	980	38.2	37.2	36.8	1172	37.1	36.4	35.7	76
22	200L2	55	980	44.1	42.9	42.4	1172	42.7	41.8	41	76
30	225M	60	980	58.8	57.2	56.4	1172	57.1	55.9	54.9	76
37	250M	65	980	70.4	68.4	67.5	1172	68.9	67.4	66.1	78
45	280S	75	980	85.0	82.6	81.5	1172	83.8	82	80.4	80
55	280M	75	980	103.3	100.4	99.1	1172	101.9	99.7	97.8	80
75	315S	80	980	139.8	135.9	134.1	1172	137.6	134.6	132.1	85
90	315M	80	980	167.3	162.6	160.5	1172	165	161.5	158.4	85
110	315L1	80	980	203.0	197.9	195.3	1172	199.3	195.1	191.4	85
132	315L2	80	980	241.0	234.2	231.1	1172	236.5	231.4	226.9	85
160	355M	95	990	288.0	279.8	275.9	1184	283.5	277.3	271.9	92
185	355M1	95	990	332.2	322.8	318.4	1184	327.4	320.3	314	92
200	355M2	95	990	359.2	349.0	344.2	1184	354.4	346.6	339.9	92
220	355L1	95	990	395.1	383.9	378.6	1184	389.8	381.3	373.9	92
250	355L2	95	990	449.0	436.2	430.2	1184	443	433.3	424.9	92

* Data are for reference only

Performance Data 400V/3Ph/50Hz

Class F, IP55 Class B Temperature Rise

KW	Motor Frame Size	Shaft (mm)	Speed (RPM)	Current		Efficiency %			Power Factor (cosφ)			Torque			Moment of inertia J=¼GD² (kg m²)	Weight of foot mount motor (Kgs)
				Full load (A)	Locked Rotor Ist/IN	100	75	50	100	75	50	Full Load (Nm)	Locked Rotor Tst/TN	Break Down Tmax/TN		
750 RPM = 8Poles																
1.10	100L2	28	680	3.2	5	73.0	73.0	70.0	0.69	0.62	0.49	15.5	1.8	2.0	0.0081	32
1.50	112M	28	690	4.2	5	75.0	75.5	72.5	0.69	0.59	0.46	20.8	1.8	2.0	0.014	40
2.2	132S	38	705	5.7	6	78.0	78.2	75.5	0.71	0.63	0.49	29.8	1.8	2.0	0.032	58
3	132M	38	705	7.5	6	79.0	80.6	79.1	0.73	0.67	0.53	40.6	1.8	2.0	0.0392	68
4	160M1	42	720	9.8	6	81.0	83.0	81.0	0.73	0.65	0.52	53.1	1.9	2.0	0.0635	98
5.5	160M2	42	720	12.9	6	83.0	84.9	83.2	0.74	0.66	0.53	73	2.0	2.0	0.0897	110
7.5	160L	42	720	16.9	6	85.5	86.0	84.5	0.75	0.67	0.54	99.5	2.0	2.0	0.127	132
11	180L	48	730	23.9	6.6	87.5	88.2	87.0	0.76	0.70	0.57	143.9	2.0	2.0	0.214	176
15	200L	55	730	32.4	6.6	88.0	90.0	88.8	0.76	0.69	0.57	196.2	2.0	2.0	0.349	232
18.5	225S	60	730	39	6.6	90.0	90.9	89.8	0.76	0.71	0.59	242	1.9	2.0	0.52	268
22	225M	60	730	45	6.6	90.5	91.4	90.4	0.78	0.72	0.61	287.8	1.9	2.0	0.62	288
30	250M	65	735	60.2	6.6	91.0	91.7	90.7	0.79	0.73	0.61	389.8	1.9	2.0	0.89	372
37	280S	75	735	73.9	6.6	91.5	92.4	91.6	0.79	0.75	0.64	480.8	1.9	2.0	1.71	466
45	280M	75	735	89.4	6.6	92.0	92.7	91.9	0.79	0.74	0.63	584.7	1.9	2.0	2.15	530
55	315S	80	735	105.6	6.6	92.8	93.0	91.6	0.81	0.77	0.67	714.6	1.8	2.0	3.790	804
75	315M	80	735	143.7	6.6	93.0	93.5	92.4	0.81	0.78	0.69	974.5	1.8	2.0	5.2	1000
90	315L1	80	735	168.9	6.6	93.8	93.8	92.6	0.82	0.78	0.68	1169.4	1.8	2.0	6.19	1032
110	315L2	80	735	206	6.4	94.0	94.0	92.9	0.82	0.78	0.69	1429.3	1.8	2.0	7.26	1102
132	355S	95	740	248	6.4	93.7	94.0	92.7	0.82	0.79	0.70	1703.5	1.8	2.0	11.85	1554
160	355M	95	740	299	6.4	94.2	94.3	93.3	0.82	0.81	0.73	2064.9	1.8	2.0	14.5	1702
185	355L1	95	740	345.7	6.4	94.2	94.5	93.3	0.82	0.81	0.73	2387.5	1.8	2.0	16.31	1930
200	355L2	95	740	368	6.4	94.5	94.6	93.6	0.83	0.81	0.73	2581.1	1.8	2.0	18.12	2250
220	355L2	95	740	404.8	6.4	94.5	94.3	92.9	0.83	0.82	0.74	2839.2	1.8	2.0	19.93	2305

* Data are for reference only

Data at various voltages

KW	Motor Frame Size	Shaft (mm)	Speed	Full Load Current @ 50Hz			Speed	Full Load Current @ 60Hz			Noise Level No Load @ 1 Metre dB(A)
			50Hz (RPM)	380V (A)	400V (A)	415V (A)	60Hz (RPM)	440V (A)	460V (A)	480V (A)	
750 RPM = 8Poles											
1.10	100L2	28	680	3.4	3.2	3.0	815	2.9	2.7	2.6	59
1.50	112M	28	690	4.4	4.2	4.0	830	3.8	3.6	3.5	61
2.2	132S	38	705	6.0	5.7	5.5	845	5.2	5.0	4.8	64
3	132M	38	705	7.9	7.5	7.2	845	6.8	6.5	6.3	64
4	160M1	42	720	10.3	9.8	9.4	864	8.9	8.5	8.1	68
5.5	160M2	42	720	13.6	12.9	12.5	864	11.8	11.2	10.8	68
7.5	160L	42	720	17.8	16.9	16.3	864	15.3	14.7	14.1	68
11	180L	48	730	25.1	23.9	23.0	875	21.7	20.8	19.9	70
15	200L	55	730	36.1	34.3	33.1	875	31.2	29.8	28.6	73
18.5	225S	60	730	41.1	39.0	37.6	875	35.5	33.9	32.5	73
22	225M	60	730	47.4	45.0	43.4	875	40.9	39.1	37.5	73
30	250M	65	735	63.4	60.2	58.1	882	54.8	52.4	50.2	75
37	280S	75	735	77.8	73.9	71.2	882	67.2	64.2	61.6	76
45	280M	75	735	94.1	89.4	86.1	882	81.2	77.7	74.5	76
55	315S	80	735	111.2	105.6	101.8	882	96.0	91.8	88.0	82
75	315M	80	735	151.3	143.7	138.5	882	130.6	125.0	119.8	82
90	315L1	80	735	178.0	168.9	163.7	882	154.4	147.6	141.5	82
110	315L2	80	735	217.0	206.0	198.5	882	187.3	179.1	171.7	82
132	355S	95	740	261.0	248.0	239.0	888	225.4	215.6	206.6	90
160	355M	95	740	315.0	299.0	288.2	888	271.8	260.0	249.1	90
185	355L1	95	740	363.9	345.7	333.2	888	314.3	300.6	288.1	90
200	355L2	95	740	387.4	368.0	354.7	888	334.6	320.0	306.7	90
220	355L2	95	740	426.2	404.8	390.2	888	368.0	352.0	337.4	90

* Data are for reference only

Dimension Drawings
Foot Mount B3

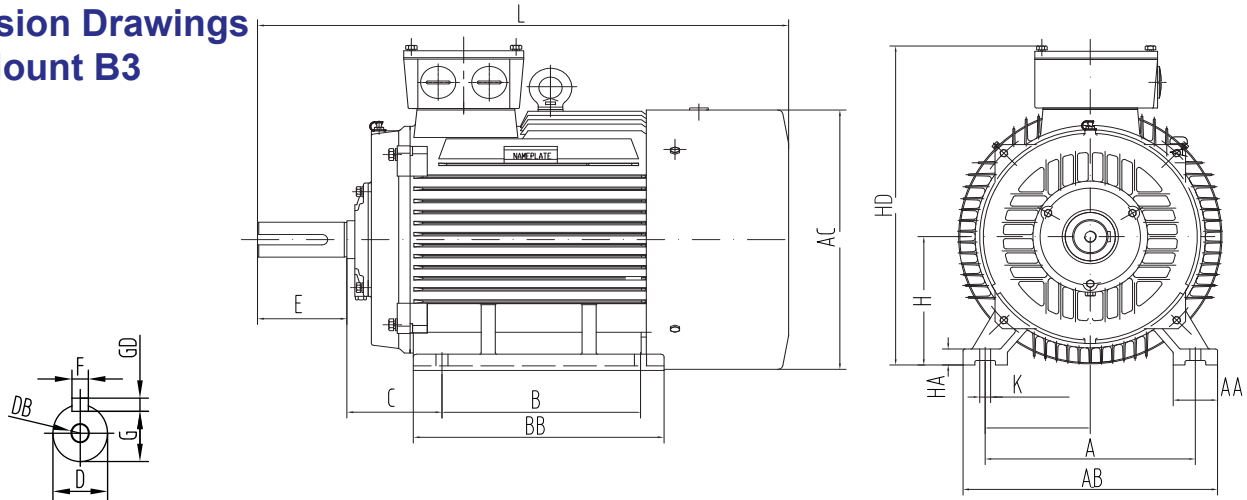

Frame	A	B	C	D	DB	E	F	G	GD	H	K	AA	AB	AC	AD	BB	HA	HD	L
71M	112	90	45	14	M5	30	5	11	5	71	7	32	150	145	80	120	8	195	242
80M	125	100	50	19	M6	40	6	15.5	6	80	10	32	162	165	145	130	10	225	285
90S	140	100	56	24	M8	50	8	20	7	90	10	34	180	180	155	140	12	245	315
90L	140	125	56	24	M8	50	8	20	7	90	10	34	180	180	155	165	12	245	340
100L	160	140	63	28	M10	60	8	24	7	100	12	39	205	205	175	186	14	270	375
112M	190	140	70	28	M10	60	8	24	7	112	12	45	230	240	185	180	13	295	400
132S	216	140	89	38	M12	80	10	33	8	132	12	55	262	275	205	186	18	345	463
132M	216	178	89	38	M12	80	10	33	8	132	12	55	262	275	205	224	18	345	501
160M	254	210	108	42	M16	110	12	37	8	160	14.5	65	318	320	260	260	20	422	610
160L	254	254	108	42	M16	110	12	37	8	160	14.5	65	318	320	260	304	20	422	655
180M	279	241	121	48	M16	110	14	42.5	9	180	14.5	70	350	380	280	311	22	450	690
180L	279	279	121	48	M16	110	14	42.5	9	180	14.5	70	350	380	280	349	22	450	730
200L	318	305	133	55	M16	110	16	49	10	200	18.5	74	390	410	315	365	26	500	770
225S	356	286	149	60	M16	140	18	53	11	225	18.5	78	435	470	340	368	28	555	801
225M*	356	311	149	55	M16	110	16	49	10	225	18.5	78	435	470	340	393	28	555	796
225M	356	311	149	60	M16	140	18	53	11	225	18.5	78	435	470	340	393	28	555	826
250M*	406	349	168	60	M16	140	18	53	11	250	24	80	490	490	370	445	30	621	927
250M	406	349	168	65	M16	140	18	58	11	250	24	80	490	490	370	445	30	621	927
280S*	457	368	190	65	M16	140	18	58	11	280	24	90	545	580	410	485	35	680	981
280S	457	368	190	75	M16	140	20	67.5	12	280	24	90	545	580	410	485	35	680	981
280M*	457	419	190	65	M16	140	18	58	11	280	24	90	545	580	410	536	35	680	1032
280M	457	419	190	75	M16	140	20	67.5	12	280	24	90	545	580	410	536	35	680	1032
315S*	508	406	216	65	M20	140	18	58	11	315	28	120	630	645	535	570	45	841	1185
315S	508	406	216	80	M20	170	22	71	14	315	28	120	630	645	535	570	45	841	1215
315M*	508	457	216	65	M20	140	18	58	11	315	28	120	630	645	535	680	45	841	1295
315M	508	457	216	80	M20	170	22	71	14	315	28	120	630	645	535	680	45	841	1325
315L*	508	508	216	65	M20	140	18	58	11	315	28	120	630	645	535	680	45	841	1295
315L	508	508	216	80	M20	170	22	71	14	315	28	120	635	645	535	680	45	841	1325
355M*	610	560	254	75	M20	140	20	67.5	12	355	28	130	725	720	650	750	52	919	1495
355M	610	560	254	95	M20	170	25	86	14	355	28	130	725	720	650	750	52	919	1525
355L*	610	630	254	75	M20	140	20	67.5	12	355	28	130	725	720	650	750	52	919	1495
355L	610	630	254	95	M20	170	25	86	14	355	28	130	725	720	650	750	52	919	1525

* For 2 Pole motors only

Dimension Drawings Flange Mount B5

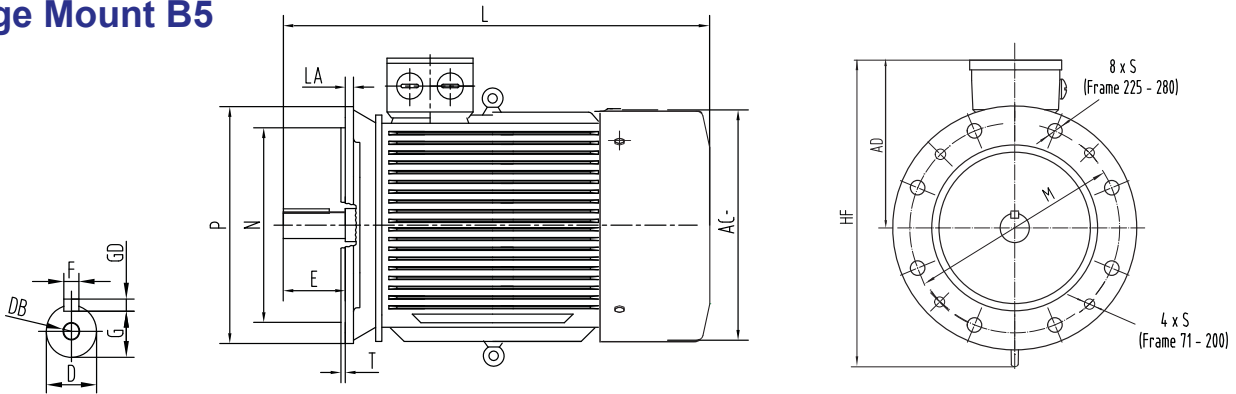

Frame	D	DB	E	F	G	GD	M	N	P	S	T	AC	AD	HF	L
71M	14	M5	30	5	11	5	130	110	160	4-Ø10	3.5	145	80	145	242
80M	19	M6	40	6	15.5	6	165	130	200	4-Ø12	3.5	165	145	230	285
90S	24	M8	50	8	20	7	165	130	200	4-Ø12	3.5	180	155	245	315
90L	24	M8	50	8	20	7	165	130	200	4-Ø12	3.5	180	155	245	340
100L	28	M10	60	8	24	7	215	180	250	4-Ø14.5	4	205	175	285	375
112M	28	M10	60	8	24	7	215	180	250	4-Ø14.5	4	240	185	300	400
132S	38	M12	80	10	33	8	365	230	300	4-Ø14.5	4	275	205	315	463
132M	38	M12	80	10	33	8	365	230	300	4-Ø14.5	4	275	205	315	501
160M	42	M16	110	12	37	8	300	250	350	4-Ø18.5	5	320	260	385	610
160L	42	M16	110	12	37	8	300	250	350	4-Ø18.5	5	320	260	385	655
180M	48	M16	110	14	42.5	9	300	250	350	4-Ø18.5	5	380	280	430	690
180L	48	M16	110	14	42.5	9	300	250	350	4-Ø18.5	5	380	280	430	730
200L	55	M16	110	16	49	10	350	300	400	4-Ø18.5	5	410	315	480	770
225S	60	M16	140	18	53	11	400	350	450	8-Ø18.5	5	470	340	535	801
225M*	55	M16	110	16	49	10	400	350	450	8-Ø18.5	5	470	340	535	796
225M	60	M16	140	18	53	11	400	350	450	8-Ø18.5	5	470	340	535	826
250M*	60	M16	140	18	53	11	500	450	550	8-Ø18.5	5	490	370	595	927
250m	65	M16	140	18	58	11	500	450	550	8-Ø18.5	5	490	370	595	927
280S*	65	M16	140	18	58	11	500	450	550	8-Ø18.5	5	580	410	650	981
280S	75	M16	140	20	67.5	12	500	450	550	8-Ø18.5	5	580	410	650	981
280M*	65	M16	140	18	58	11	500	450	550	8-Ø18.5	5	580	410	650	1032
280M	75	M16	140	20	67.5	12	500	450	550	8-Ø18.5	5	580	410	650	1032

* For 2 Pole motors only

Dimension Drawings Vertical Mount V1

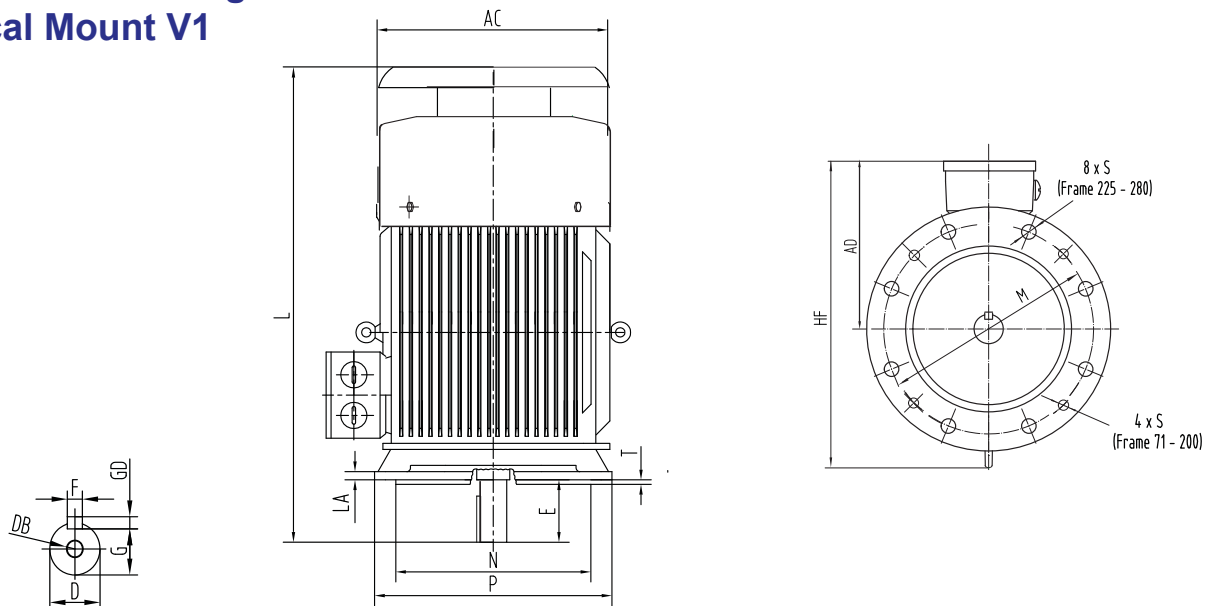

Frame	D	DB	E	F	G	GD	M	N	P	S	T	AC	AD	HF	L
71M	14	M5	30	5	11	5	130	110	160	4-Ø10	3.5	145	80	210	287
80M	19	M6	40	6	15.5	6	165	130	200	4-Ø12	3.5	165	145	250	340
90S	24	M8	50	8	20	7	165	130	200	4-Ø12	3.5	180	155	260	360
90L	24	M8	50	8	20	7	165	130	200	4-Ø12	3.5	180	155	260	385
100L	28	M10	60	8	24	7	215	180	250	4-Ø14.5	4	205	175	300	420
112M	28	M10	60	8	24	7	215	180	250	4-Ø14.5	4	240	185	320	450
132S	38	M12	80	10	33	8	365	230	300	4-Ø14.5	4	275	205	340	513
132M	38	M12	80	10	33	8	365	230	300	4-Ø14.5	4	275	205	340	551
160M	42	M16	110	12	37	8	300	250	350	4-Ø18.5	5	320	260	400	665
160L	42	M16	110	12	37	8	300	250	350	4-Ø18.5	5	320	260	400	710
180M	48	M16	110	14	42.5	9	300	250	350	4-Ø18.5	5	380	280	500	750
180L	48	M16	110	14	42.5	9	300	250	350	4-Ø18.5	5	380	280	500	790
200L	55	M16	110	16	49	10	350	300	400	4-Ø18.5	5	410	315	550	835
225S	60	M16	140	18	53	11	400	350	450	8-Ø18.5	5	470	340	610	905
225M*	55	M16	110	16	49	10	400	350	450	8-Ø18.5	5	470	340	610	900
225M	60	M16	140	18	53	11	400	350	450	8-Ø18.5	5	470	340	610	930
250M*	60	M16	140	18	53	11	500	450	550	8-Ø18.5	5	490	370	650	1035
250M	65	M16	140	18	58	11	500	450	550	8-Ø18.5	5	490	370	650	1035
280S*	65	M16	140	18	58	11	500	450	550	8-Ø18.5	5	580	410	720	1115
280S	75	M16	140	20	67.5	12	500	450	550	8-Ø18.5	5	580	410	720	1115
280M*	65	M16	140	18	58	11	500	450	550	8-Ø18.5	5	580	410	720	1157
280M	75	M16	140	20	67.5	12	500	450	550	8-Ø18.5	5	580	410	720	1157
315S*	65	M20	140	18	58	11	600	550	660	8-Ø24	6	645	535	900	1310
315S	80	M20	170	22	71	14	600	550	660	8-Ø24	6	645	535	900	1340
315M*	65	M20	140	18	58	11	600	550	660	8-Ø24	6	645	535	900	1425
315M	80	M20	170	22	71	14	600	550	660	8-Ø24	6	645	535	900	1455
315L*	65	M20	140	18	58	11	600	550	660	8-Ø24	6	645	535	900	1425
315L	80	M20	170	22	71	14	600	550	660	8-Ø24	6	645	535	900	1455
355M*	75	M20	140	20	67.5	12	740	680	800	8-Ø24	6	720	650	1010	1640
355M	95	M20	170	25	86	14	740	680	800	8-Ø24	6	720	650	1010	1670
355L*	75	M20	140	20	67.5	12	740	680	800	8-Ø24	6	720	650	1010	1640
355L	95	M20	170	25	86	14	740	680	800	8-Ø24	6	720	650	1010	1670

* For 2 Poles only

**Dimension Drawings
Face Mount B14A**

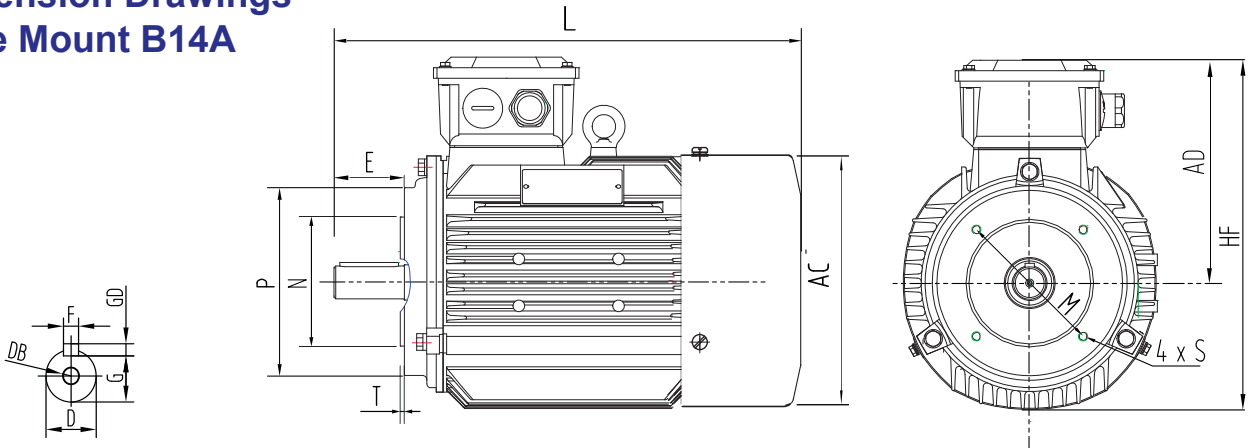

Frame	D	DB	E	F	G	GD	M	N	P	S	T	AC	AD	HF	L
71M	14	M5	30	5	11	5	85	70	105	M5 X 4	2.5	145	80	145	242
80M	19	M6	40	6	15.5	6	100	80	120	M6 X 4	3	165	145	230	295
90S	24	M8	50	8	20	7	115	95	140	M6 X 4	3	180	155	245	315
90L	24	M8	50	8	20	7	115	95	140	M8 X 4	3	180	155	245	340
100L	28	M10	60	8	24	7	130	110	160	M8 X 4	3.5	205	175	285	375
112M	28	M10	60	8	24	7	130	110	160	M8 X 4	3.5	240	185	300	400
132S	38	M12	80	10	33	8	165	130	200	M10X4	3.5	275	205	340	470
132M	38	M12	80	10	33	8	165	130	200	M10X4	3.5	275	205	340	510

**Dimension Drawings Airstream
Application Motor**

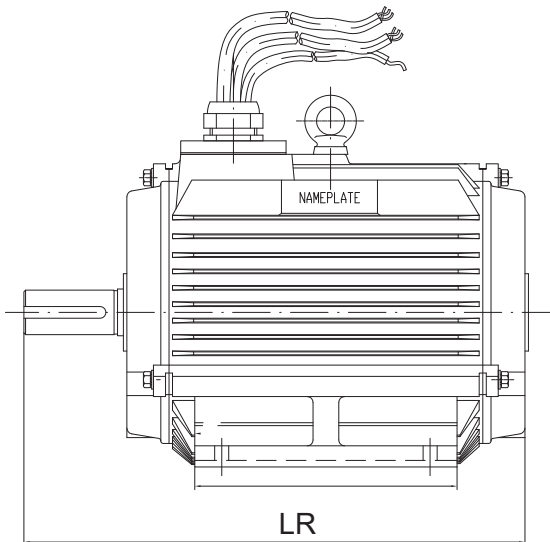

Frame	LR (mm)	Frame	LR (mm)
71	214	225M*	700
80	245	225M	730
90S	265	250M*	800
90L	290	250M	800
100L	325	280S*	855
112M	340	280S	855
132S	395	280M*	905
132M	435	280M	905
160M	530	315S*	1015
160L	575	315S	1045
180M	595	315M*	1125
180L	630	315M	1155
200L	675	355L*	1330
225S	705	355L	1360

* 2 Pole motors only

Performance Data 400V/3Ph/50Hz

Class F IP55 Class B Temperature Rise

KW	Motor Frame Size	Shaft (mm)	Speed (RPM)	Current		Efficiency %			Power Factor (cosφ)			Torque			Moment of inertia J=¼GD ² (kg m ²)	Weight of foot mount motor (Kgs)
				Full load (A)	Locked Rotor Ist/IN	100	75	50	100	75	50	Full Load (Nm)	Locked Rotor Tst/TN	Break Down Tmax/TN		
3000 RPM = 2Poles																
0.75	80M1	19	2885	1.7	6.8	77.4	80.5	79.0	0.82	0.80	0.69	2.48	2.3	2.3	0.001	15.5
1.1	80M2	19	2885	2.4	7.3	79.6	82.5	81.3	0.83	0.79	0.67	3.64	2.3	2.3	0.0013	16
1.5	90S	24	2885	3.2	7.6	81.3	83.7	82.4	0.84	0.80	0.69	4.96	2.3	2.3	0.002	20.5
2.2	90L	24	2890	4.5	7.8	83.2	85.9	85.2	0.85	0.84	0.74	7.27	2.3	2.3	0.003	23.5
3	100L	28	2895	5.9	8.1	84.6	86.9	86.6	0.87	0.86	0.78	9.9	2.3	2.3	0.004	31
4	112M	28	2895	7.6	8.3	85.8	87.9	87.3	0.88	0.85	0.76	13.19	2.3	2.3	0.006	40
5.5	132S1	38	2920	10.4	8	87.0	89.1	87.8	0.88	0.84	0.75	17.89	2.2	2.3	0.013	59
7.5	132S2	38	2915	13.8	7.8	88.1	90.0	89.3	0.89	0.87	0.79	24.57	2.2	2.3	0.015	63
11	160M1	42	2945	20	7.9	89.4	90.3	89.1	0.89	0.90	0.85	35.67	2.2	2.3	0.049	107
15	160M2	42	2945	26.9	8	90.3	91.6	90.6	0.89	0.91	0.86	48.64	2.2	2.3	0.056	117
18.5	160L	42	2940	33	8.1	90.9	92.2	91.3	0.89	0.90	0.85	60.09	2.2	2.3	0.0648	137
22	180M	48	2960	39.1	8.2	91.3	91.9	90.5	0.89	0.91	0.86	70.98	2.2	2.3	0.081	166
30	200L1	55	2965	52.9	7.5	92.0	92.7	91.5	0.89	0.88	0.81	96.62	2.2	2.3	0.163	225
37	200L2	55	2965	64.9	7.5	92.5	93.3	92.3	0.89	0.87	0.80	119.17	2.2	2.3	0.172	244
45	225M	55	2965	78.6	7.6	92.9	93.5	92.4	0.89	0.89	0.83	144.94	2.2	2.3	0.302	292
55	250M	60	2965	95.7	7.6	93.2	93.6	92.5	0.89	0.90	0.84	176.55	2.2	2.3	0.42	373
75	280S	65	2980	129.7	6.9	93.8	94.0	92.8	0.89	0.90	0.84	240.35	2.0	2.3	0.986	490
90	280M	65	2970	155.1	7	94.1	94.5	93.4	0.89	0.90	0.85	288.42	2.0	2.3	1.04	537
110	315S	65	2980	187.1	7.1	94.3	94.3	93.0	0.90	0.90	0.85	352.51	2.0	2.2	1.33	830
132	315M	65	2980	223.8	7.1	94.6	94.9	93.8	0.90	0.91	0.86	423.02	2.0	2.2	1.5	850
160	315L1	65	2980	267.7	7.1	94.8	95.3	94.5	0.91	0.92	0.88	512.75	2.0	2.2	1.67	945
200	315L2	65	2980	333.9	7.1	95.0	94.9	93.6	0.91	0.90	0.84	640.94	2.0	2.2	1.88	1070
250	355M	75	2985	417.4	7.1	95.0	94.7	93.1	0.91	0.90	0.86	799.83	2.0	2.2	4.02	1550
315	355L	75	2985	526	7.1	95.0	94.9	93.4	0.91	0.92	0.87	1007.79	2.0	2.2	4.86	1780
355	355L2	80	2985	592.7	7.1	95.0	94.5	93.5	0.91	0.92	0.88	1135.76	2.0	2.2	7.55	1780
375	355L3	80	2985	626.1	7.1	95.0	94.4	93.1	0.91	0.92	0.88	1199.75	2.0	2.2	9.52	1855

* Data are for reference only

- Data upon request

Data at various voltages

KW	Motor Frame Size	Shaft (mm)	Speed	Full Load Current @ 50Hz			Speed	Full Load Current @ 60Hz			Noise Level No Load @ 1 Metre dB(A)
			50Hz (RPM)	380V (A)	400V (A)	415V (A)	60Hz (RPM)	440V (A)	460V (A)	480V (A)	
3000 RPM = 2Poles											
0.75	80M1	19	2885	1.8	1.7	1.7	3461	1.8	1.7	1.7	62
1.10	80M2	19	2885	2.5	2.4	2.4	3461	2.4	2.3	2.3	62
1.50	90S	24	2885	3.3	3.2	3.1	3461	3.1	3.1	3.0	67
2.2	90L	24	2890	4.7	4.5	4.4	3467	4.4	4.3	4.3	67
3	100L	28	2895	6.2	5.9	5.8	3473	5.8	5.7	5.5	74
4	112M	28	2895	8	7.6	7.5	3473	7.6	7.5	7.3	77
5.5	132S1	38	2920	10.9	10.4	10.2	3503	10.3	10.1	9.9	79
7.5	132S2	38	2915	14.5	13.8	13.6	3497	13.8	13.5	13.2	79
11	160M1	42	2945	21	20	19.7	3533	20.2	19.7	19.4	81
15	160M2	42	2945	28.3	26.9	26.6	3533	27.5	26.9	26.4	81
18.5	160L	42	2940	34.7	33	32.5	3527	33.6	32.8	32.2	81
22	180M	48	2960	41.1	39.1	38.5	3551	39.9	39.0	38.2	83
30	200L1	55	2965	55.7	52.9	52.1	3557	54.0	52.8	51.7	84
37	200L2	55	2965	68.3	64.9	64.0	3557	66.1	64.7	63.4	84
45	225M	55	2965	82.7	78.6	77.5	3557	79.9	78.1	76.6	86
55	250M	60	2965	100.7	95.7	94.4	3557	97.6	95.5	93.6	89
75	280S	65	2980	136.5	129.7	127.9	3575	132.2	129.3	126.7	91
90	280M	65	2970	163.3	155.1	152.9	3563	157.1	153.6	150.6	91
110	315S	65	2980	196.9	187.1	184.4	3275	189.9	185.7	181.9	92
132	315M	65	2980	235.6	223.8	220.6	3275	226.7	221.6	217.2	92
160	315L1	65	2980	281.8	267.7	263.8	3575	271.8	265.7	260.3	92
200	315L2	65	2980	351.5	333.9	329.1	3575	338.4	330.7	324.0	92
250	355M	75	2985	439.4	417.4	411.4	3581	422.9	413.4	405.0	100
315	355L	75	2985	553.6	526	518.3	3581	533.0	520.9	510.4	100
355	355L2	80	2985	623.9	592.7	584.1	3581	600.6	587.0	575.2	104
375	355L3	80	2985	659.1	626.1	617.0	3581	634.4	620.1	607.5	104

* Data are for reference only

Performance Data 400V/3Ph/50Hz

Class F, IP55 Class B Temperature Rise

KW	Motor Frame Size	Shaft (mm)	Speed (RPM)	Current		Efficiency %			Power Factor (cosφ)			Torque			Moment of inertia J=¼GD² (kg m²)	Weight of foot mount motor (Kgs)
				Full load (A)	Locked Rotor Ist/IN	100	75	50	100	75	50	Full Load (Nm)	Locked Rotor Tst/TN	Break Down Tmax/TN		
1500 RPM = 4Poles																
0.75	80M2	19	1435	1.8	6.5	79.6	82.3	80.5	0.76	0.70	0.57	4.99	2.3	2.3	0.002	16
1.10	90S	24	1435	2.5	6.6	81.4	83.8	82.4	0.77	0.73	0.60	7.32	2.3	2.3	0.003	21
1.50	90L	24	1440	3.4	6.9	82.8	85.2	84.4	0.78	0.75	0.63	9.95	2.3	2.3	0.004	24.5
2.2	100L1	28	1455	4.7	7.5	84.3	86.2	85.2	0.80	0.75	0.62	14.44	2.3	2.3	0.008	32
3	100L2	28	1455	6.2	7.6	85.5	87.6	86.9	0.81	0.77	0.66	19.69	2.3	2.3	0.009	35
4	112M	28	1455	8.2	7.7	86.6	88.4	87.7	0.81	0.78	0.67	26.25	2.3	2.3	0.013	43
5.5	132S	38	1460	11	7.5	87.7	89.4	88.4	0.82	0.77	0.66	35.98	2.0	2.3	0.029	61
7.5	132M	38	1460	14.7	7.4	88.7	90.1	89.4	0.83	0.79	0.69	49.06	2.0	2.3	0.037	73
11	160M	42	1470	21.3	7.5	89.8	91.1	90.3	0.83	0.82	0.72	71.46	2.2	2.3	0.077	105
15	160L	42	1470	28.4	7.5	90.6	91.6	91.0	0.84	0.81	0.71	97.12	2.2	2.3	0.101	128
18.5	180M	48	1475	34.4	7.7	91.2	92.2	91.6	0.85	0.85	0.77	119.78	2.2	2.3	0.152	156
22	180L	48	1475	40.1	7.8	91.6	92.6	92.0	0.85	0.85	0.77	142.44	2.2	2.3	0.187	175
30	200L	55	1480	55.2	7.2	92.3	93.1	92.3	0.85	0.83	0.74	193.58	2.2	2.3	0.285	236
37	225S	60	1485	67	7.3	92.7	93.3	92.4	0.86	0.85	0.78	237.95	2.2	2.3	0.473	285
45	225M	60	1485	81.1	7.4	93.1	93.8	92.9	0.86	0.84	0.76	289.39	2.2	2.3	0.554	315
55	250M	65	1480	98.7	7.4	93.5	93.8	92.9	0.86	0.83	0.74	352.5	2.2	2.3	0.751	395
75	280S	75	1490	132.4	6.7	94.0	94.2	93.2	0.87	0.86	0.78	480.7	2.2	2.3	1.92	552
90	280M	75	1490	156.7	6.9	94.2	94.6	93.6	0.88	0.87	0.79	576.84	2.2	2.3	2.32	595
110	315S	80	1490	188.8	6.9	94.5	94.6	93.5	0.89	0.88	0.81	705.03	2.2	2.2	2.34	865
132	315M	80	1490	226.1	6.9	94.7	95.1	94.1	0.89	0.88	0.82	846.04	2.2	2.2	2.58	910
160	315L1	80	1490	270.4	7.1	94.9	95.3	94.5	0.90	0.89	0.83	1025.5	2.2	2.2	2.96	1050
200	315L2	80	1490	337.3	7.1	95.1	95.3	94.4	0.90	0.89	0.85	1281.88	2.2	2.2	3.46	1140
250	355M	95	1490	421.6	7.1	95.1	94.8	93.7	0.90	0.90	0.85	1602.35	2.2	2.2	6.6	1540
315	355L	95	1490	531.2	7.1	95.1	95.3	94.3	0.90	0.91	0.87	2018.96	2.2	2.2	7.55	1780
355	355L2	110	1490	611.6	7.0	95.1	95.2	94.2	0.89	0.90	0.88	2275.3	2.2	2.2	15.78	1800
375	355L3	110	1490	646.1	7.0	95.1	95.3	94.2	0.88	0.90	0.88	2403.5	2.2	2.2	17.17	1935

* Data are for reference only

- Data upon request

Data at various voltages

KW	Motor Frame Size	Shaft (mm)	Speed	Full Load Current @ 50Hz			Speed	Full Load Current @ 60Hz			Noise Level
			50Hz (RPM)	380V (A)	400V (A)	415V (A)	60Hz (RPM)	440V (A)	460V (A)	480V (A)	No Load @ 1 Metre dB(A)
1500 RPM = 4Poles											
0.75	80M2	19	1435	1.9	1.8	1.8	1721	1.7	1.7	1.7	56
1.1	90S	24	1435	2.7	2.5	2.5	1721	2.5	2.4	2.4	59
1.5	90L	24	1440	3.5	3.4	3.3	1727	3.4	3.3	3.2	59
2.2	100L1	28	1455	4.9	4.7	4.7	1745	4.6	4.5	4.4	64
3	100L2	28	1455	6.6	6.2	6.2	1745	6.2	6.1	6.0	64
4	112M	28	1455	8.7	8.2	8.1	1745	8.3	8.1	8.0	65
5.5	132S	38	1460	11.6	11	10.9	1751	11.0	10.8	10.6	71
7.5	132M	38	1460	15.5	14.7	14.5	1751	14.8	14.5	14.2	71
11	160M	42	1470	22.4	21.3	21.0	1763	21.4	21.0	20.6	73
15	160L	42	1470	29.9	28.4	28.1	1763	28.8	28.2	27.7	73
18.5	180M	48	1475	36.3	34.4	34.0	1769	34.6	33.8	33.2	76
22	180L	48	1475	42.9	40.1	40.3	1769	41.1	40.2	39.4	76
30	200L	55	1480	58.1	55.2	54.5	1775	55.6	54.5	53.4	76
37	225S	60	1485	70.5	67	66.1	1781	67.9	66.5	65.2	78
45	225M	60	1485	85.4	81.1	80.1	1781	82.1	80.3	78.8	78
55	250M	65	1480	103.9	98.7	97.4	1775	99.7	97.6	95.8	79
75	280S	75	1490	139.3	132.4	130.6	1787	133.9	131.0	128.5	80
90	280M	75	1490	165	156.7	154.6	1787	158.8	155.3	152.3	80
110	315S	80	1490	198.7	188.8	186.1	1787	191.0	186.7	183.1	88
132	315M	80	1490	238	226.1	222.9	1787	229.2	224.1	219.7	88
160	315L1	80	1490	284.6	270.4	266.5	1787	274.8	268.6	263.2	88
200	315L2	80	1490	355	337.3	332.5	1787	342.0	334.4	327.7	88
250	355M	95	1490	443.8	421.6	415.6	1787	427.5	418.0	409.6	95
315	355L	95	1490	559.2	531.2	523.7	1787	538.7	526.7	516.2	95
355	355L2	110	1490	637.3	611.6	596.9	1787	613.8	600.2	588.3	102
375	355L3	110	1490	680.8	646.1	637.9	1787	655.5	641.2	628.7	102

* Data are for reference only

Performance Data 400V/3Ph/50Hz

Class F, IP55 Class B Temperature Rise

KW	Motor Frame Size	Shaft (mm)	Speed (RPM)	Current		Efficiency %			Power Factor (cosφ)			Torque			Moment of inertia J=1/4GD ² (kg m ²)	Weight of foot mount motor (Kgs)
				Full load (A)	Locked Rotor Ist/IN	100	75	50	100	75	50	Full Load (Nm)	Locked Rotor Tst/TN	Break Down Tmax/TN		
1000 RPM = 6Poles																
0.75	90S	24	950	2	5.8	75.9	77.2	74.5	0.71	0.63	0.50	7.54	2.1	2.1	0.004	20
1.10	90L	24	950	2.8	5.9	78.1	79.9	78.2	0.72	0.65	0.52	11.06	2.1	2.1	0.0053	23.5
1.50	100L	28	955	3.8	6	79.8	82.2	80.9	0.72	0.68	0.55	15	2.1	2.1	0.011	30
2.2	112M	28	955	5.4	6	81.8	83.3	81.5	0.72	0.67	0.54	22	2.1	2.1	0.015	39
3	132S	38	975	7.2	6.2	83.3	85.5	83.9	0.72	0.67	0.54	29.38	2.0	2.1	0.032	54
4	132M1	38	975	9.2	6.8	84.6	86.6	85.2	0.74	0.67	0.54	39.18	2.0	2.1	0.039	64
5.5	132M2	38	975	12.3	7.1	86.0	87.9	86.7	0.75	0.68	0.55	53.87	2.0	2.1	0.049	71
7.5	160M	42	980	15.9	6.7	87.2	89.5	88.4	0.78	0.75	0.62	73.09	2.1	2.1	0.096	99
11	160L	42	980	22.6	6.9	88.7	90.0	89.2	0.79	0.75	0.63	107.19	2.1	2.1	0.127	123
15	180L	48	980	29.4	7.2	89.7	91.3	90.7	0.82	0.80	0.69	146.17	2.0	2.1	0.201	163
18.5	200L1	55	985	36.9	7.2	90.4	91.8	91.0	0.80	0.78	0.66	179.36	2.1	2.1	0.325	210
22	200L2	55	980	43.1	7.3	90.9	92.1	91.5	0.81	0.78	0.68	213.3	2.1	2.1	0.371	227
30	225M	60	980	57.6	7.1	91.7	93.0	92.2	0.82	0.81	0.72	290.8	2.0	2.1	0.533	275
37	250M	65	990	69.8	7.1	92.2	92.7	92.0	0.83	0.80	0.70	356.92	2.1	2.1	0.877	365
45	280S	75	990	82.4	7.2	92.7	93.4	92.5	0.85	0.82	0.73	434.09	2.1	2	1.85	480
55	280M	75	990	99.2	7.2	93.1	93.9	93.0	0.86	0.83	0.74	530.55	2.1	2	2.12	525
75	315S	80	995	137.5	6.7	93.7	94.2	93.2	0.84	0.83	0.74	719.85	2.0	2	2.61	810
90	315M	80	995	162.6	6.7	94.0	94.5	93.5	0.85	0.83	0.74	863.82	2.0	2	3.04	875
110	315L1	80	995	198.1	6.7	94.3	94.8	93.9	0.85	0.83	0.74	1055.78	2.0	2	3.71	1010
132	315L2	80	995	234.2	6.7	94.6	95.2	94.3	0.86	0.84	0.75	1266.93	2.0	2	4.24	1060
160	355M1	95	995	283.3	6.7	94.8	94.5	93.2	0.86	0.86	0.79	1535.68	2.0	2	7.44	1455
200	355M2	95	995	353.3	6.7	95.0	94.9	93.8	0.86	0.86	0.79	1919.60	2.0	2	9.1	1590
250	355L	95	995	441.7	6.7	95.0	95.2	94.2	0.86	0.87	0.80	2399.50	2.0	2	10.8	1750
315	355L3	110	995	549.5	6.8	95.0	95.0	94.2	0.86	0.88	0.79	3023.40	2.0	2	21.1	1930

* Data are for reference only

- Data upon request

Data at various voltages

KW	Motor Frame Size	Shaft (mm)	Speed	Full Load Current @ 50Hz			Speed	Full Load Current @ 60Hz			Noise Level No Load @ 1 Metre dB(A)
			50Hz (RPM)	380V (A)	400V (A)	415V (A)	60Hz (RPM)	440V (A)	460V (A)	480V (A)	
1000 RPM = 6Poles											
0.75	90S	24	950	2.1	2	2.0	1139	1.9	1.9	1.9	57
1.1	90L	24	950	3	2.8	2.8	1139	2.6	2.6	2.5	57
1.5	100L	28	955	4	3.8	3.7	1145	3.5	3.5	3.4	61
2.2	112M	28	955	5.7	5.4	5.3	1145	5.1	5.0	4.9	65
3	132S	38	975	7.6	7.2	7.2	1169	6.9	6.8	6.7	69
4	132M1	38	975	9.7	9.2	9.1	1169	9.0	8.9	8.7	69
5.5	132M2	38	975	13	12.3	12.2	1169	12.0	11.8	11.6	69
7.5	160M	42	980	16.8	15.9	15.7	1175	15.7	15.4	15.2	73
11	160L	42	980	23.9	22.6	22.4	1175	22.7	22.2	21.9	73
15	180L	48	980	31	29.4	29.1	1175	29.8	29.2	28.7	73
18.5	200L1	55	985	38.9	36.9	36.5	1181	36.9	36.2	35.6	73
22	200L2	55	980	45.4	43.1	42.6	1175	43.4	42.5	41.7	73
30	225M	60	980	60.6	57.6	56.9	1175	57.6	56.4	55.4	74
37	250M	65	990	73.5	69.8	68.9	1187	70.3	68.9	67.6	76
45	280S	75	990	86.8	82.4	81.4	1187	83.0	81.2	79.7	78
55	280M	75	990	104.4	99.2	97.8	1187	100.3	98.1	96.3	78
75	315S	80	995	144.8	137.5	135.8	1193	139.1	136.2	133.7	83
90	315M	80	995	171.1	162.6	160.5	1193	164.9	161.5	158.4	83
110	315L1	80	995	208.5	198.1	195.5	1193	199.7	195.5	191.8	83
132	315L2	80	995	246.5	234.2	231.1	1193	236.9	231.9	227.5	83
160	355M1	95	995	298.2	283.3	279.5	1193	287.2	281.0	275.7	85
200	355M2	95	995	371.9	353.3	348.7	1193	359.0	351.3	344.6	85
250	355L	95	995	464.9	441.7	435.9	1193	448.4	439.1	430.8	85
315	355L3	110	995	585.8	549.5	549.2	1193	565.4	553.4	542.9	91

* Data are for reference only

Performance Data 400V/3Ph/50Hz

Class F, IP55 Class B Temperature Rise

KW	Motor Frame Size	Shaft (mm)	Speed (RPM)	Current		Efficiency %			Power Factor (cosφ)			Torque			Moment of inertia J=1/4GD ² (kg m ²)	Weight of foot mount motor (Kgs)
				Full load (A)	Locked Rotor Ist/IN	100	75	50	100	75	50	Full Load (Nm)	Locked Rotor Tst/TN	Break Down Tmax/TN		
3000 RPM = 2Poles																
0.75	80M1	19	2885	1.6	7.0	80.7	80.9	78.5	0.82	0.78	0.66	2.48	2.3	2.3	0.0010	15
1.1	80M2	19	2885	2.3	7.3	82.7	83.1	82.2	0.83	0.78	0.65	3.64	2.2	2.3	0.0013	17
1.5	90S	24	2895	3	7.6	84.2	84.6	83.8	0.84	0.81	0.73	4.95	2.2	2.3	0.0021	23
2.2	90L	24	2900	4.4	7.6	85.9	86.3	85.5	0.85	0.82	0.75	7.24	2.2	2.3	0.0028	27
3	100L	28	2890	5.7	7.8	87.1	87.5	86.9	0.87	0.83	0.76	9.91	2.2	2.3	0.0046	32
4	112M	28	2900	7.4	8.3	88.1	88.5	87.5	0.88	0.86	0.80	13.17	2.2	2.3	0.0074	41
5.5	132S1	38	2925	10.1	8.3	89.2	88.2	86.8	0.88	0.83	0.76	17.96	2.0	2.3	0.0145	63
7.5	132S2	38	2925	13.7	7.9	90.1	89.9	88.3	0.89	0.86	0.80	24.49	2.0	2.3	0.0176	70
11	160M1	42	2945	19.6	8.1	91.2	91.9	91.1	0.89	0.88	0.82	35.67	2.0	2.3	0.0513	117
15	160M2	42	2950	26.5	8.1	91.9	92.3	91.6	0.89	0.86	0.81	48.56	2.0	2.3	0.0654	124
18.5	160L	42	2945	32.5	8.2	92.4	92.8	92.7	0.89	0.89	0.85	59.99	2.0	2.3	0.0760	146
22	180M	48	2955	38.5	8.2	92.7	92.5	91.8	0.89	0.87	0.81	71.10	2.0	2.3	0.1183	178
30	200L1	55	2965	52.2	7.6	93.3	93.0	91.8	0.89	0.83	0.75	96.63	2.0	2.3	0.1649	246
37	200L2	55	2965	64.0	7.6	93.7	93.7	93.2	0.89	0.86	0.79	119.17	2.0	2.3	0.1945	260
45	225M	55	2965	76.8	7.7	94.0	94.7	94.0	0.89	0.87	0.81	144.94	2.0	2.3	0.3097	327
55	250M	60	2970	93.6	7.7	94.3	94.2	93.5	0.89	0.87	0.80	176.85	2.0	2.3	0.4168	413
75	280S	65	2975	127.0	7.1	94.7	94.2	93.2	0.89	0.86	0.80	240.76	1.8	2.3	0.6849	527
90	280M	65	2975	151.9	7.1	95.0	94.8	94.1	0.89	0.86	0.79	288.91	1.8	2.3	0.8015	573
110	315S	65	2980	185.3	7.1	95.2	95.4	95.0	0.90	0.88	0.83	352.52	1.8	2.3	1.5305	945
132	315M	65	2975	221.9	7.1	95.4	95.4	95.0	0.90	0.89	0.84	423.73	1.8	2.3	1.7253	980
160	315L1	65	2975	265.4	7.2	95.6	95.8	95.5	0.91	0.87	0.82	513.61	1.8	2.3	2.0592	1040
185	315L	65	2975	306.7	7.2	95.7	95.8	95.3	0.91	0.88	0.82	593.90	1.8	2.2	2.3375	1100
200	315L2	65	2975	331.2	7.2	95.8	95.9	95.6	0.91	0.89	0.84	642.02	1.8	2.2	2.5045	1135
220	315L3	65	2980	364.2	7.2	95.8	95.6	95.4	0.91	0.89	0.85	705.00	1.6	2.2	3.1254	1250
250	355M	75	2980	413.9	7.2	95.8	95.4	94.6	0.91	0.87	0.82	801.17	1.6	2.2	3.1254	1650
280	355L1	75	2980	463.6	7.2	95.8	95.4	95.0	0.91	0.87	0.82	891.30	1.6	2.2	3.7504	1700
315	355L	75	2980	515.9	7.2	95.8	95.6	94.9	0.91	0.88	0.82	1009.48	1.6	2.2	3.7504	1790
355	355L2	80	2980	587.8	7.2	95.8	95.6	95.0	0.91	0.89	0.84	1130.10	1.6	2.2	7.7020	1790
375	355L3	80	2980	620.9	7.2	95.8	95.6	95.1	0.91	0.89	0.85	1193.80	1.6	2.2	8.1221	1950

* Data are for reference only

Data at various voltages

KW	Motor Frame Size	Shaft (mm)	Speed	Full Load Current @ 50Hz			Speed	Full Load Current @ 60Hz			Noise Level No Load @ 1 Metre dB(A)
			50Hz (RPM)	380V (A)	400V (A)	415V (A)	60Hz (RPM)	440V (A)	460V (A)	480V (A)	
3000 RPM = 2Poles											
0.75	80M1	19	2885	1.7	1.6	1.5	3460	1.8	1.4	1.3	62
1.1	80M2	19	2885	2.4	2.3	2.2	3460	2.5	2.0	1.9	62
1.5	90S	24	2895	3.2	3.0	2.9	3470	3.3	2.6	2.5	67
2.2	90L	24	2900	4.6	4.4	4.2	3480	4.8	3.8	3.7	67
3	100L	28	2890	6.0	5.7	5.5	3465	6.3	5.0	4.8	74
4	112M	28	2900	7.8	7.4	7.1	3480	8.1	6.4	6.2	77
5.5	132S1	38	2925	10.6	10.1	9.7	3510	11.1	8.8	8.4	79
7.5	132S2	38	2925	14.4	13.7	13.2	3510	15.1	11.9	11.4	79
11	160M1	42	2945	20.6	19.6	18.9	3530	21.6	17.0	16.3	81
15	160M2	42	2950	27.9	26.5	25.5	3540	29.2	23.0	22.1	81
18.5	160L	42	2945	34.2	32.5	31.3	3530	35.8	28.3	27.1	81
22	180M	48	2955	40.5	38.5	37.1	3545	42.4	33.5	32.1	83
30	200L1	55	2965	54.9	52.2	50.3	3555	57.4	45.4	43.5	84
37	200L2	55	2965	67.4	64.0	61.7	3555	70.4	55.7	53.3	84
45	225M	55	2965	80.8	76.8	74.0	3555	84.5	66.8	64.0	86
55	250M	60	2970	98.5	93.6	90.2	3560	103.0	81.4	78.0	89
75	280S	65	2975	133.7	127.0	122.4	3570	139.7	110.4	105.8	91
90	280M	65	2975	159.9	151.9	146.4	3570	167.1	132.1	126.6	91
110	315S	65	2980	195.1	185.3	178.6	3575	203.8	161.1	154.4	92
132	315M	65	2975	233.6	221.9	213.9	3570	244.1	193.0	184.9	92
160	315L1	65	2975	279.4	265.4	255.8	3570	291.9	230.8	221.2	92
185	315L	65	2975	322.8	306.7	295.6	3570	337.4	266.7	255.6	92
200	315L2	65	2975	348.6	331.2	319.2	3570	364.3	288.0	276.0	92
220	315L3	65	2980	383.4	364.2	351.0	3575	400.6	316.7	303.5	100
250	355M	75	2980	435.7	413.9	398.9	3575	455.3	359.9	344.9	100
280	355L1	75	2980	488.0	463.6	446.8	3575	510.0	403.1	386.3	100
315	355L	75	2980	543.0	515.9	497.3	3575	567.5	448.6	429.9	100
355	355L2	80	2980	618.7	587.8	566.6	3575	646.6	511.1	489.8	104
375	355L3	80	2980	653.6	620.9	598.5	3575	683.0	539.9	517.4	104

* Data are for reference only

Performance Data 400V/3Ph/50Hz

Class F, IP55 Class B Temperature Rise

KW	Motor Frame Size	Shaft (mm)	Speed (RPM)	Current			Efficiency %			Power Factor (cosφ)			Torque			Moment of inertia J=¼GD ² (kg m ²)	Weight of foot mount motor (Kgs)
				Full load (A)	Locked Rotor Ist/IN	Locked Rotor Ist/IN	100	75	50	100	75	50	Full Load (Nm)	Locked Rotor Tst/TN	Break Down Tmax/TN		
1500 RPM = 4Poles																	
0.75	80M2	19	1435	1.7	6.6	6.6	82.5	82.7	82.0	0.75	0.71	0.66	4.99	2.3	2.3	0.0023	17
1.1	90S	24	1435	2.5	6.8	6.8	84.1	84.3	83.8	0.76	0.73	0.65	7.32	2.3	2.3	0.0037	24
1.5	90L	24	1435	3.3	7.0	7.0	85.3	85.5	84.8	0.77	0.73	0.64	9.98	2.3	2.3	0.0048	29
2.2	100L1	28	1450	4.6	7.6	7.6	86.7	86.9	85.8	0.81	0.77	0.68	14.49	2.3	2.3	0.0090	34
3	100L2	28	1450	6	7.6	7.6	87.7	87.9	87.1	0.82	0.78	0.70	19.76	2.3	2.3	0.0120	37
4	112M	28	1455	8	7.8	7.8	88.6	88.9	88.7	0.82	0.77	0.69	26.25	2.2	2.3	0.0175	51
5.5	132S	38	1460	10.6	7.9	7.9	89.6	89.2	88.5	0.83	0.78	0.68	35.98	2.0	2.3	0.0350	66
7.5	132M	38	1460	14.3	7.5	7.5	90.4	90.1	89.3	0.84	0.74	0.65	49.06	2.0	2.3	0.0447	77
11	160M	42	1470	20.4	7.7	7.7	91.4	91.2	90.3	0.85	0.78	0.68	71.46	2.2	2.3	0.0974	113
15	160L	42	1470	27.4	7.8	7.8	92.1	91.6	90.6	0.86	0.78	0.66	97.12	2.2	2.3	0.1239	132
18.5	180M	48	1475	33.5	7.8	7.8	92.6	93.0	92.2	0.86	0.82	0.73	119.78	2.0	2.3	0.1811	171
22	180L	48	1475	39.7	7.8	7.8	93.0	93.7	92.8	0.86	0.82	0.73	142.44	2.0	2.3	0.2242	188
30	200L	55	1475	53.8	7.3	7.3	93.6	93.4	92.7	0.86	0.82	0.73	194.24	2.0	2.3	0.3631	253
37	225S	60	1480	66.1	7.4	7.4	93.9	94.2	93.4	0.86	0.81	0.71	238.75	2.0	2.3	0.5589	297
45	225M	60	1480	80.2	7.4	7.4	94.2	94.2	94.1	0.86	0.83	0.76	290.37	2.0	2.3	0.6351	324
55	250M	65	1485	97.6	7.4	7.4	94.6	95.2	94.4	0.86	0.81	0.71	353.70	2.2	2.3	0.8994	419
75	280S	75	1485	129.5	6.9	6.9	95.0	95.0	94.6	0.88	0.84	0.77	482.32	2.0	2.3	1.6251	583
90	280M	75	1485	155.0	6.9	6.9	95.2	95.3	94.8	0.88	0.85	0.78	578.79	2.0	2.3	1.9672	624
110	315S	80	1485	187.0	7.0	7.0	95.4	95.8	95.2	0.89	0.86	0.80	707.41	2.0	2.2	3.2735	930
132	315M	80	1485	223.9	7.0	7.0	95.6	95.6	95.4	0.89	0.87	0.82	848.89	2.0	2.2	3.6959	970
160	315L1	80	1485	270.8	7.1	7.1	95.8	96.0	95.7	0.89	0.88	0.83	1028.96	2.0	2.2	4.2239	1090
185	315L	80	1485	312.9	7.1	7.1	95.9	96.0	95.8	0.89	0.88	0.82	1189.70	2.0	2.2	4.8575	1100
200	315L2	80	1485	334.1	7.1	7.1	96.0	96.1	95.9	0.90	0.89	0.86	1286.20	2.0	2.2	5.9135	1155
220	315L3	80	1490	367.5	7.1	7.1	96.0	95.8	95.6	0.90	0.88	0.86	1410.10	2.0	2.2	6.3016	1400
250	355M	95	1490	417.6	7.1	7.1	96.0	96.3	95.9	0.90	0.89	0.85	1602.35	2.0	2.2	6.3016	1760
280	355L1	95	1490	467.8	7.1	7.1	96.0	96.1	95.5	0.90	0.88	0.86	1794.60	2.0	2.2	7.9821	1800
315	355L	95	1490	526.2	7.1	7.1	96.0	96.2	95.4	0.90	0.89	0.85	2018.96	2.0	2.2	10.5721	1810
355	355L2	110	1490	606.5	7.1	7.1	96.0	96.2	95.5	0.88	0.86	0.83	2260.20	1.7	2.2	15.1082	1880
375	355L3	110	1490	640.7	7.1	7.1	96.0	96.2	95.4	0.88	0.87	0.85	2387.50	1.7	2.2	16.4413	1880

* Data are for reference only

Data at various voltages

KW	Motor Frame Size	Shaft (mm)	Speed	Full Load Current @ 50Hz			Speed	Full Load Current @ 60Hz			Noise Level No Load @ 1 Metre dB(A)
			50Hz (RPM)	380V (A)	400V (A)	415V (A)	60Hz (RPM)	440V (A)	460V (A)	480V (A)	
1500 RPM = 4Poles											
0.75	80M2	19	1435	1.8	1.7	1.6	1720	1.5	1.5	1.4	56
1.10	90S	24	1435	2.6	2.5	2.4	1720	2.3	2.2	2.1	59
1.50	90L	24	1435	3.5	3.3	3.2	1720	3.0	2.9	2.8	59
2.20	100L1	28	1450	4.8	4.6	4.4	1740	4.2	4.0	3.8	64
3.00	100L2	28	1450	6.3	6.0	5.8	1740	5.5	5.2	5.0	64
4.0	112M	28	1455	8.4	8.0	7.7	1745	7.3	7.0	6.7	65
5.5	132S	38	1460	11.2	10.6	10.2	1750	9.6	9.2	8.8	71
7.5	132M	38	1460	15.0	14.3	13.8	1750	13.0	12.4	11.9	71
11.0	160M	42	1470	21.5	20.4	19.7	1760	18.5	17.7	17.0	73
15.0	160L	42	1470	28.8	27.4	26.4	1760	24.9	23.8	22.8	73
18.5	180M	48	1475	35.3	33.5	32.3	1770	30.5	29.1	27.9	76
22	180L	48	1475	41.8	39.7	38.3	1770	36.1	34.5	33.1	76
30	200L	55	1475	56.6	53.8	51.9	1770	48.9	46.8	44.8	76
37	225S	60	1480	69.6	66.1	63.7	1775	60.1	57.5	55.1	78
45	225M	60	1480	84.4	80.2	77.3	1775	72.9	69.7	66.8	78
55	250M	65	1485	102.7	97.6	94.1	1780	88.7	84.9	81.3	79
75	280S	75	1485	136.3	129.5	124.8	1780	117.7	112.6	107.9	80
90	280M	75	1485	163.2	155.0	149.4	1780	140.9	134.8	129.2	80
110	315S	80	1485	196.8	187.0	180.2	1780	170.0	162.6	155.8	88
132	315M	80	1485	235.7	223.9	215.8	1780	203.5	194.7	186.6	88
160	315L1	80	1485	285.1	270.8	261.0	1780	246.2	235.5	225.7	88
185	315L	80	1485	329.3	312.9	301.6	1780	284.5	272.1	260.8	88
200	315L2	80	1485	351.7	334.1	322.0	1780	303.7	290.5	278.4	88
220	315L3	80	1490	386.9	367.5	354.2	1785	334.1	319.6	306.3	95
250	355M	95	1490	439.6	417.6	402.5	1785	379.6	363.1	348.0	95
280	355L1	95	1490	492.4	467.8	450.9	1785	425.3	406.8	389.8	95
315	355L	95	1490	553.9	526.2	507.2	1785	478.4	457.6	438.5	95
355	355L2	110	1490	638.5	606.5	584.6	1785	551.4	527.4	505.4	102
375	355L3	110	1490	674.4	640.7	617.5	1785	582.5	557.1	533.9	102

* Data are for reference only

Performance Data 400V/3Ph/50Hz

Class F, IP55 Class B Temperature Rise

KW	Motor Frame Size	Shaft (mm)	Speed (RPM)	Current			Efficiency %			Power Factor (cosφ)			Torque			Moment of inertia J= $\frac{1}{4}GD^2$ (kg m ²)	Weight of foot mount motor (Kgs)
				Full load (A)	Locked Rotor Ist/IN		100	75	50	100	75	50	Full Load (Nm)	Locked Rotor Tst/TN	Break Down Tmax/TN		
1000 RPM = 6Poles																	
0.75	90S	24	955	1.9	6.0	78.9	79.2	78.2	0.71	0.63	0.51	7.50	2.0	2.1	0.0048	22	
1.1	90L	24	955	2.7	6.0	81.0	81.3	80.6	0.73	0.68	0.53	11.00	2.0	2.1	0.0071	28	
1.5	100L	28	955	3.6	6.5	82.5	82.9	82.2	0.73	0.68	0.54	15.00	2.0	2.1	0.0126	31	
2.2	112M	28	950	5.1	6.6	84.3	84.8	84.1	0.74	0.68	0.56	22.12	2.0	2.1	0.0191	42	
3	132S	38	970	6.8	6.8	85.6	85.0	83.4	0.74	0.65	0.52	29.54	2.0	2.1	0.0357	58	
4	132M1	38	970	9	6.8	86.8	85.9	84.1	0.74	0.63	0.50	39.38	2.0	2.1	0.0477	69	
5.5	132M2	38	970	12.1	7.0	88.0	86.6	85.0	0.75	0.63	0.50	54.15	2.0	2.1	0.0630	76	
7.5	160M	42	975	15.4	7.0	89.1	89.1	87.5	0.79	0.69	0.56	73.46	2.0	2.1	0.1119	105	
11	160L	42	975	21.9	7.2	90.3	90.1	89.2	0.80	0.74	0.63	107.74	2.0	2.1	0.1492	129	
15	180L	48	980	29.4	7.3	91.2	91.8	91.1	0.81	0.77	0.66	146.17	2.0	2.1	0.2574	168	
18.5	200L1	55	980	35.9	7.3	91.7	91.9	91.3	0.81	0.78	0.69	180.28	2.0	2.1	0.3881	218	
22	200L2	55	980	42.6	7.4	92.2	92.2	91.3	0.81	0.84	0.76	214.39	2.0	2.1	0.4478	240	
30	225M	60	985	56.1	6.9	92.9	93.3	92.8	0.83	0.81	0.78	290.86	2.0	2.1	0.6342	295	
37	250M	65	985	68.1	7.1	93.3	93.4	92.6	0.84	0.77	0.67	358.73	2.0	2.1	1.0787	389	
45	280S	75	985	81.5	7.3	93.7	93.4	92.8	0.85	0.80	0.71	436.29	2.0	2	1.7050	497	
55	280M	75	985	98.1	7.3	94.1	94.0	93.3	0.86	0.79	0.70	533.25	2.0	2	2.0619	537	
75	315S	80	990	136.2	6.6	94.6	95.0	94.5	0.84	0.80	0.70	723.48	2.0	2	3.9210	830	
90	315M	80	990	161.0	6.7	94.9	94.9	94.4	0.85	0.78	0.68	868.18	2.0	2	4.2711	910	
110	315L1	80	990	196.5	6.7	95.1	95.2	94.9	0.85	0.82	0.75	1061.11	2.0	2	5.4614	1035	
132	315L2	80	990	232.2	6.8	95.4	95.3	94.8	0.86	0.80	0.72	1273.33	2.0	2	6.5817	1120	
160	355M1	95	990	280.9	6.8	95.6	95.4	94.5	0.86	0.82	0.76	1543.43	1.8	2	10.3039	1530	
185	355M	95	990	324.4	6.8	95.7	95.5	94.8	0.86	0.80	0.72	1784.60	1.8	2	11.7758	1630	
200	355M2	95	990	346.4	6.8	95.8	95.6	94.8	0.87	0.81	0.74	1929.29	1.8	2	11.7758	1640	
220	355L1	95	990	381.0	6.8	95.8	95.6	94.9	0.87	0.82	0.71	2122.20	1.8	2	13.5875	1840	
250	355L	95	990	432.9	6.8	95.8	95.8	95.6	0.87	0.85	0.79	2411.62	1.8	2	15.2860	1930	
280	355L2	110	990	484.9	6.8	95.8	95.5	94.5	0.87	0.85	0.78	2701.00	1.8	2	20.6243	1970	
315	355L3	110	990	551.9	6.8	95.8	95.1	94.5	0.86	0.82	0.77	3008.25	1.8	2	20.6243	1970	

* Data are for reference only

Data at various voltages

KW	Motor Frame Size	Shaft (mm)	Speed	Full Load Current @ 50Hz			Speed	Full Load Current @ 60Hz			Noise Level No Load @ 1 Metre dB(A)
			50Hz (RPM)	380V (A)	400V (A)	415V (A)	60Hz (RPM)	440V (A)	460V (A)	480V (A)	
1000 RPM = 6Poles											
0.75	90S	24	955	2.0	1.9	1.8	1145	1.7	1.7	1.6	57
1.1	90L	24	955	2.8	2.7	2.6	1145	2.5	2.3	2.3	57
1.5	100L	28	955	3.8	3.6	3.5	1145	3.3	3.1	3.0	61
2.2	112M	28	950	5.4	5.1	4.9	1140	4.6	4.4	4.3	65
3	132S	38	970	7.2	6.8	6.6	1160	6.2	5.9	5.7	69
4	132M1	38	970	9.5	9.0	8.7	1160	8.2	7.8	7.5	69
5.5	132M2	38	970	12.7	12.1	11.7	1160	11.0	10.5	10.1	69
7.5	160M	42	975	16.2	15.4	14.8	1170	14.0	13.4	12.8	73
11	160L	42	975	23.1	21.9	21.1	1170	19.9	19.0	18.3	73
15	180L	48	980	30.9	29.4	28.3	1175	26.7	25.6	24.5	73
18.5	200L1	55	980	37.8	35.9	34.6	1175	32.6	31.2	29.9	73
22	200L2	55	980	44.8	42.6	41.1	1175	38.7	37.0	35.5	73
30	225M	60	985	59.1	56.1	54.1	1180	51.0	48.8	46.8	74
37	250M	65	985	71.7	68.1	65.6	1180	61.9	59.2	56.8	76
45	280S	75	985	85.8	81.5	78.6	1180	74.1	70.9	67.9	78
55	280M	75	985	103.3	98.1	94.6	1180	89.2	85.3	81.8	78
75	315S	80	990	143.4	136.2	131.3	1185	123.8	118.4	113.5	83
90	315M	80	990	169.5	161.0	155.2	1185	146.4	140.0	134.2	83
110	315L1	80	990	206.8	196.5	189.4	1185	178.6	170.9	163.8	83
132	315L2	80	990	244.4	232.2	223.8	1185	211.1	201.9	193.5	83
160	355M1	80	990	295.7	280.9	270.7	1185	255.4	244.3	234.1	85
185	355M	95	990	341.5	324.4	312.7	1185	294.9	282.1	270.3	85
200	355M2	95	990	364.6	346.4	333.9	1185	314.9	301.2	288.7	85
220	355L1	95	990	401.0	381.0	367.2	1185	346.4	331.3	317.5	85
250	355L	95	990	455.7	432.9	417.3	1185	393.5	376.4	360.8	85
280	355L2	110	990	510.4	484.9	467.4	1185	440.8	421.7	404.1	85
315	355L3	110	990	580.9	551.9	532.0	1185	501.7	479.9	459.9	91

* Data are for reference only

Dimension Drawings
Foot Mount B3

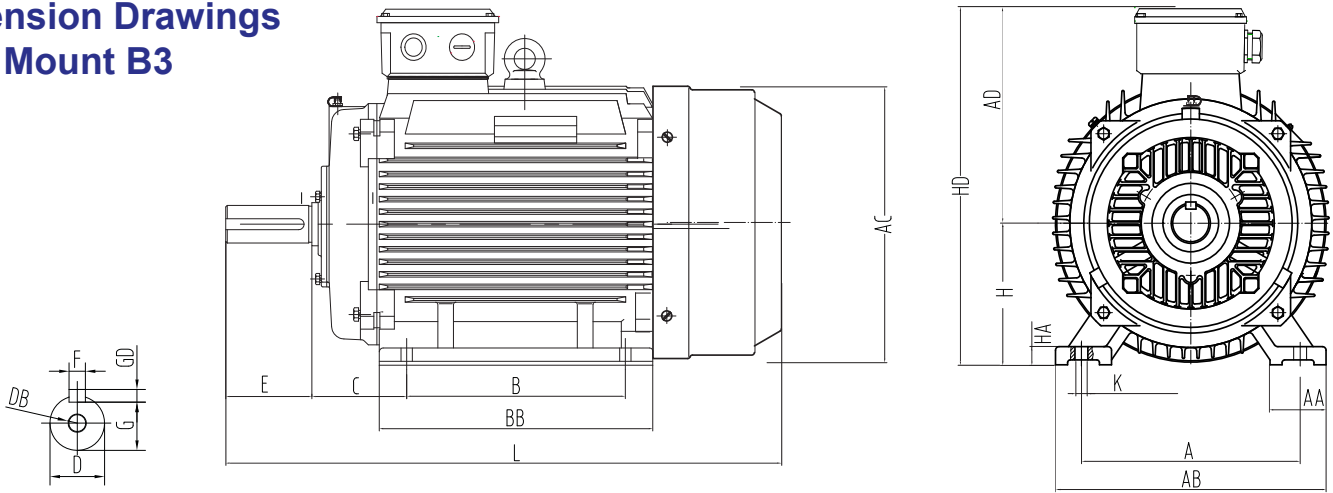

Frame	A	AA	B	C	D	DB	E	F	G	GD	H	K	AB	AC	AD	HD	L	BB	HA
80	125	32	100	50	19	M6	40	6	15.5	6	80	10	160	165	145	225	295	135	10
90S	140	34	100	56	24	M8	50	8	20	7	90	10	180	180	165	255	345	170	12
90L	140	34	125	56	24	M8	50	8	20	7	90	10	180	180	165	255	385	210	12
100L	160	39	140	63	28	M10	60	8	24	7	100	12	200	205	175	275	390	186	14
112M	190	45	140	70	28	M10	60	8	24	7	112	12	230	225	190	302	440	200	15
132S	216	55	140	89	38	M12	80	10	33	8	132	12	265	270	220	352	475	190	18
132M	216	55	178	89	38	M12	80	10	33	8	132	12	265	270	220	352	510	230	18
160M	254	65	210	108	42	M16	110	12	37	8	160	14.5	315	320	260	420	610	260	20
160L	254	65	254	108	42	M16	110	12	37	8	160	14.5	315	320	260	420	655	304	20
180M	279	70	241	121	48	M16	110	14	42.5	9	180	14.5	355	360	265	445	680	311	22
180L	279	70	279	121	48	M16	110	14	42.5	9	180	14.5	355	360	265	445	715	349	22
200L	318	74	305	133	55	M16	110	16	49	10	200	18.5	395	400	305	505	770	379	26
225S	356	78	286	149	60	M16	140	18	53	11	225	18.5	435	450	325	550	795	375	28
225M*	356	78	311	149	55	M16	110	16	49	10	225	18.5	435	450	325	550	800	400	28
225M	356	78	311	149	60	M16	140	18	53	11	225	18.5	435	450	325	550	825	400	28
250M*	406	80	349	168	60	M16	140	18	53	11	250	24	490	510	380	630	890	445	30
250M	406	80	349	168	65	M16	140	18	58	11	250	24	490	510	380	630	890	445	30
280S*	457	90	368	190	65	M16	140	18	58	11	280	24	545	550	395	675	975	485	35
280S	457	90	368	190	75	M16	140	20	67.5	12	280	24	545	550	395	675	975	485	35
280M*	457	90	419	190	65	M16	140	18	58	11	280	24	545	550	395	675	1025	536	35
280M	457	90	419	190	75	M16	140	20	67.5	12	280	24	545	550	395	675	1025	536	35
315S*	508	120	406	216	65	M20	140	18	58	11	315	28	635	630	540	855	1180	570	45
315S	508	120	406	216	80	M20	170	22	71	14	315	28	635	630	540	855	1180	570	45
315M*	508	120	457	216	65	M20	140	18	58	11	315	28	635	630	540	855	1215	610	45
315M	508	120	457	216	80	M20	170	22	71	14	315	28	635	630	540	855	1215	610	45
315L*	508	120	508	216	65	M20	140	18	58	11	315	28	635	630	540	855	1320	680	45
315L	508	120	508	216	80	M20	170	22	71	14	315	28	635	630	540	855	1320	680	45
355M*	610	130	560	254	75	M20	140	20	67.5	12	355	28	735	715	645	1000	1420	690	52
355M	610	130	560	254	95	M20	170	25	86	14	355	28	735	715	645	1000	1420	690	52
355L*	610	130	630	254	75	M20	140	20	67.5	12	355	28	735	715	645	1000	1530	750	52
355L	610	130	630	254	95	M20	170	25	86	14	355	28	735	715	645	1000	1530	750	52
355L2*	610	130	630	254	80	M20	170	22	71	14	355	28	735	715	645	1000	1530	750	52
355L2	610	130	630	254	110	M20	210	28	100	14	355	28	735	715	645	1000	1570	750	52

* For 2 Pole motors only

Dimension Drawings
Flange Mount B5

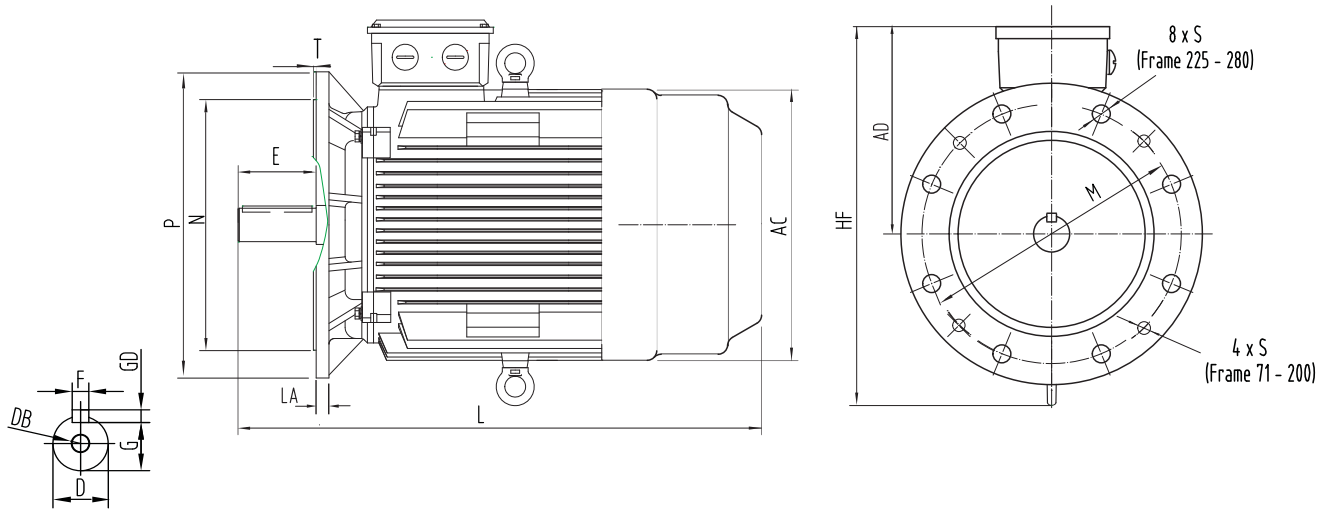

Frame	AC	AD	D	DB	E	F	G	GD	HF	L	LA	M	N	P	S	T
80	165	145	19	M6	40	6	15.5	6	245	295	12	165	130	200	12	3.5
90S	180	165	24	M8	50	8	20.0	7	265	345	12	165	130	200	12	3.5
90L	180	165	24	M8	50	8	20.0	7	265	385	12	165	130	200	12	3.5
100L	205	175	28	M10	60	8	24.0	7	300	390	14	215	180	250	15	4.0
112M	225	190	28	M10	60	8	24.0	7	315	425	14	215	180	250	15	4.0
132S	270	220	38	M12	80	10	33.0	8	370	475	14	265	230	300	15	4.0
132M	270	220	38	M12	80	10	33.0	8	370	510	14	265	230	300	15	4.0
160M	320	260	42	M16	110	12	37.0	8	435	610	16	300	250	350	19	5.0
160L	320	260	42	M16	110	12	37.0	8	435	655	16	300	250	350	19	5.0
180M	360	265	48	M16	110	14	42.5	9	500	680	18	300	250	350	19	5.0
180L	360	265	48	M16	110	14	42.5	9	250	715	18	300	250	350	19	5.0
200L	400	305	55	M16	110	16	49.0	10	570	770	18	350	300	400	19	5.0
225S	450	325	60	M16	140	18	53.0	11	615	795	20	400	350	450	19	5.0
225M*	450	325	55	M16	110	16	49.0	10	615	825	20	400	350	450	19	5.0
225M	450	325	60	M16	140	18	53.0	11	615	825	20	400	350	450	19	5.0
250M*	510	380	60	M16	140	18	53.0	11	715	890	22	500	450	550	19	5.0
250M	510	380	65	M16	140	18	58.0	11	715	890	22	500	450	550	19	5.0
280S*	550	395	65	M16	140	18	58.0	11	760	975	22	500	450	550	19	5.0
280S	550	395	75	M16	140	20	67.5	12	760	975	22	500	450	550	19	5.0
280M*	550	395	65	M16	140	18	58.0	11	760	1025	22	500	450	550	19	5.0
280M	550	395	75	M16	140	20	67.5	12	760	1025	22	500	450	550	19	5.0
315S*	630	540	65	M20	140	18	58.0	11	970	1180	25	600	550	660	24	6.0
315S	630	540	80	M20	170	22	71.0	14	970	1180	25	600	550	660	24	6.0
315M*	630	540	65	M20	140	18	58.0	11	970	1215	25	600	550	660	24	6.0
315M	630	540	80	M20	170	22	71.0	14	970	1215	25	600	550	660	24	6.0
315L*	630	540	65	M20	140	18	58.0	11	970	1320	25	600	550	660	24	6.0
315L	630	540	80	M20	170	22	71.0	14	970	1320	25	600	550	660	24	6.0
355M*	715	645	75	M20	140	20	67.5	12	1135	1420	32	740	680	800	24	6.0
355M	715	645	95	M20	170	25	86.0	14	1135	1420	32	740	680	800	24	6.0
355L*	715	645	75	M20	140	20	67.5	12	1135	1530	32	740	680	800	24	6.0
355L	715	645	95	M20	170	25	86.0	14	1135	1530	32	740	680	800	24	6.0
355L2*	715	645	80	M20	170	22	71.0	14	1135	1530	32	740	680	800	24	6.0
355L2	715	645	110	M20	210	28	100	14	1135	1570	32	740	680	800	24	6.0

* For 2 Pole motors only

Dimension Drawings
Vertical Mount V1

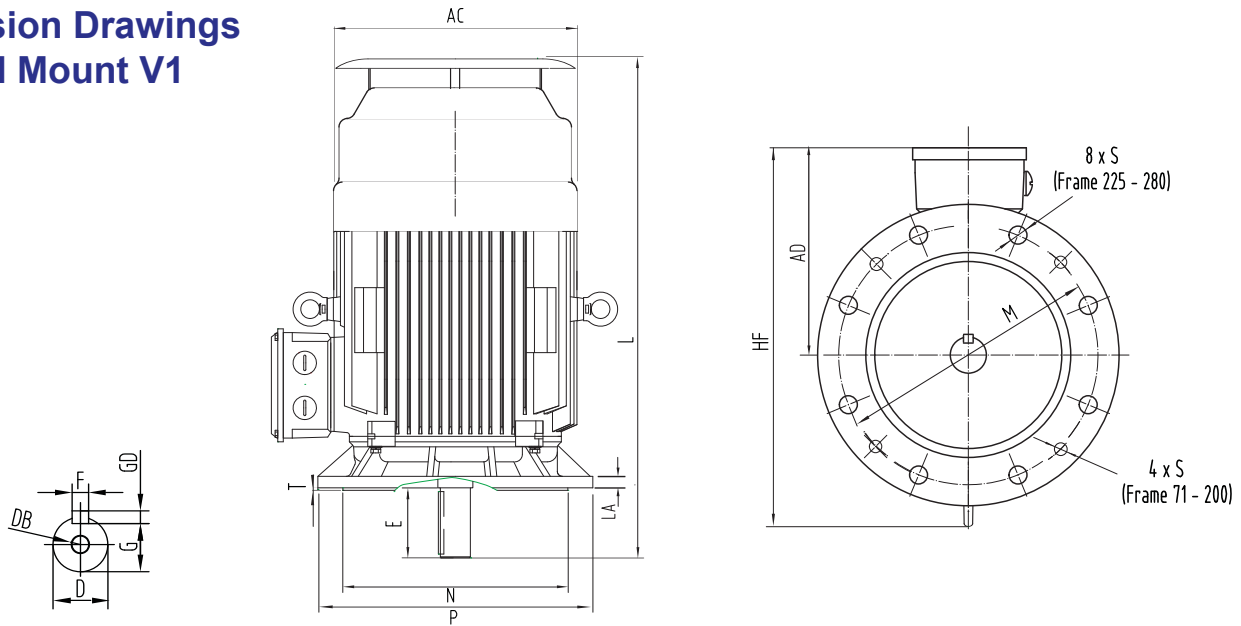

Frame	AC	AD	D	DB	E	F	G	GD	HF	L	LA	M	N	P	S	T
80	165	145	19	M6	40	6	15.5	6	245	345	12	165	130	200	12	3.5
90S	180	165	24	M8	50	8	20.0	7	265	400	12	165	130	200	12	3.5
90L	180	165	24	M8	50	8	20.0	7	265	430	12	165	130	200	12	3.5
100L	205	175	28	M10	60	8	24.0	7	300	480	14	215	180	250	15	4.0
112M	225	190	28	M10	60	8	24.0	7	315	518	14	215	180	250	15	4.0
132S	270	220	38	M12	80	10	33.0	8	370	560	14	265	230	300	15	4.0
132M	270	220	38	M12	80	10	33.0	8	370	600	14	265	230	300	15	4.0
160M	320	260	42	M16	110	12	37.0	8	435	730	16	300	250	350	19	5.0
160L	320	260	42	M16	110	12	37.0	8	435	760	16	300	250	350	19	5.0
180M	360	265	48	M16	110	14	42.5	9	500	800	18	300	250	350	19	5.0
180L	360	265	48	M16	110	14	42.5	9	250	848	18	300	250	350	19	5.0
200L	400	305	55	M16	110	16	49.0	10	570	845	18	350	300	400	19	5.0
225S	450	325	60	M16	140	18	53.0	11	615	915	20	400	350	450	19	5.0
225M*	450	325	55	M16	110	16	49.0	10	615	910	20	400	350	450	19	5.0
225M	450	325	60	M16	140	18	53.0	11	615	940	20	400	350	450	19	5.0
250M*	510	380	60	M16	140	18	53.0	11	715	1035	22	500	450	550	19	5.0
250M	510	380	65	M16	140	18	58.0	11	715	1035	22	500	450	550	19	5.0
280S*	550	395	65	M16	140	18	58.0	11	760	1115	22	500	450	550	19	5.0
280S	550	395	75	M16	140	20	67.5	12	760	1115	22	500	450	550	19	5.0
280M*	550	395	65	M16	140	18	58.0	11	760	1157	22	500	450	550	19	5.0
280M	550	395	75	M16	140	20	67.5	12	760	1157	22	500	450	550	19	5.0
315S*	630	540	65	M20	140	18	58.0	11	970	1340	25	600	550	660	24	6.0
315S	630	540	80	M20	170	22	71.0	14	970	1340	25	600	550	660	24	6.0
315M*	630	540	65	M20	140	18	58.0	11	970	1425	25	600	550	660	24	6.0
315M	630	540	80	M20	170	22	71.0	14	970	1450	25	600	550	660	24	6.0
315L*	630	540	65	M20	140	18	58.0	11	970	1425	25	600	550	660	24	6.0
315L	630	540	80	M20	170	22	71.0	14	970	1450	25	600	550	660	24	6.0
355M*	715	645	75	M20	140	20	67.5	12	1135	1640	32	740	680	800	24	6.0
355M	715	645	95	M20	170	25	86.0	14	1135	1670	32	740	680	800	24	6.0
355L*	715	645	75	M20	140	20	67.5	12	1135	1640	32	740	680	800	24	6.0
355L	715	645	95	M20	170	25	86.0	14	1135	1670	32	740	680	800	24	6.0
355L2*	715	645	80	M20	170	22	71.0	14	1135	1920	32	740	680	800	24	6.0
355L2	715	645	110	M20	210	28	100	14	1135	1970	32	740	680	800	24	6.0

* For 2 Pole motors only

**Dimension Drawings
Face Mount B14A**

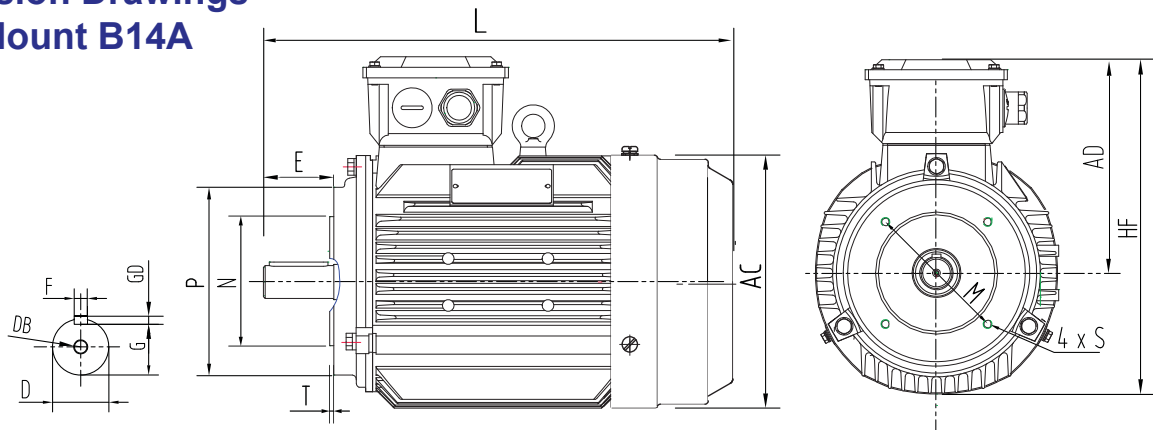

Frame	D	DB	E	F	G	GD	M	N	P	S	T	AC	AD	HF	L
80M	19	M6	40	6	15.5	6	100	80	120	M6 X 4	3	167	165	225	295
90S	24	M8	50	8	20	7	115	95	140	M8 X 4	3	190	175	225	345
90L	24	M8	50	8	20	7	115	95	140	M8 X 4	3	190	175	255	385
100L	28	M10	60	8	24	7	130	110	160	M8 X 4	3.5	215	190	275	390
112M	28	M10	60	8	24	7	130	110	160	M8 X 4	3.5	240	190	300	425
132S	38	M12	80	10	33	8	165	130	200	M10X4	3.5	275	220	350	510
132M	38	M12	80	10	33	8	165	130	200	M10X4	3.5	275	220	350	510

**Dimension Drawings
Airstream Application Motor**

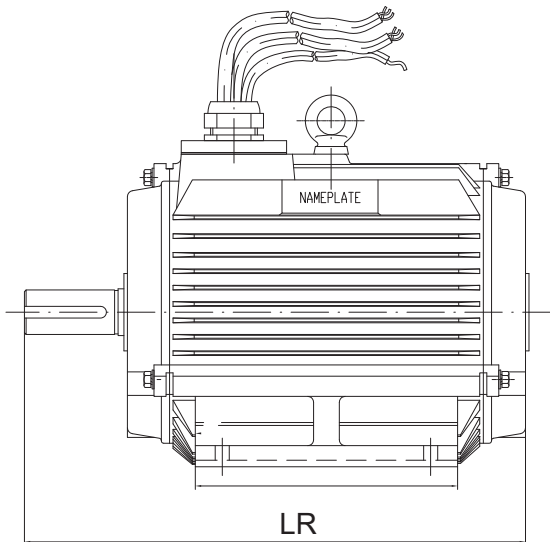

Frame	LR (mm)	Frame	LR (mm)
80	250	225M	730
90S	300	250M*	800
90L	330	250M	800
100L	380	280S*	855
112M	405	280S	855
132S	430	280M*	905
132M	470	280M	905
160M	570	315S*	1015
160L	600	315S	1045
180M	630	315M*	1125
180L	680	315M	1155
200L	675	355L*	1330
225S	705	355L	1360
225M*	700		

* 2 Pole motors only

DBA Series , 2 Speed , Pole change

High Speed	Low Speed	High Speed					Low Speed				Weight of motor (Kgs)
KW	KW	Frame	r/min	A	Cos	Eff%	r/min	A	Cos	Eff%	
3000/1500 RPM = 2/4 Poles											
Separate Windings - Y/Y											
0.8	0.16	80M	2840	2.0	0.82	70.0	1400	0.44	0.73	64.0	15
1.2	0.24	90S	2840	2.7	0.85	74.0	1400	0.7	0.73	71.0	18
1.7	0.34	90L	2840	3.5	0.87	75.0	1400	1.4	0.73	72.0	22
2.4	0.48	100L	2880	4.9	0.87	82.0	1400	1.5	0.74	76.0	31
3.3	0.66	112M	2800	6.5	0.87	82.0	1400	1.6	0.74	76.0	42
4.4	0.88	132S1	2880	8.1	0.89	82.0	1400	2.1	0.74	76.0	56
6.1	1.2	132S2	2900	11.5	0.91	83.0	1440	3.1	0.74	80.0	57
8.3	1.7	160M1	2900	15.9	0.91	85.0	1440	4.8	0.77	83.0	106
12	2.4	160M2	2900	20.1	0.91	86.0	1440	6.9	0.75	85.0	107
17	3.4	160L	2900	30	0.91	87.0	1440	7.3	0.76	86.0	130
20	4	180M	2900	36.3	0.91	87.0	1440	10.1	0.75	86.0	162
24	4.8	200L1	2900	42.4	0.91	87.0	1440	13.8	0.75	86.0	230
33	6.6	200L2	2940	70.2	0.91	87.0	1470	15.8	0.76	86.0	232
41	8.2	225M	2940	83.2	0.91	87.0	1470	18.9	0.76	86.0	309
50	10	250M	2950	85.8	0.91	87.0	1480	26.1	0.76	86.0	412
61	12	280S	2950	108.0	0.90	87.0	1480	27.8	0.76	87.0	501
83	17	280M	2950	146.5	0.91	87.2	1480	36.5	0.76	87.0	576
99	20	315S	2955	174.6	0.90	87.0	1480	42.9	0.77	88.0	889
121	24	315M1	2955	212.8	0.91	88.0	1480	51.8	0.77	88.0	982
145	29	315M2	2955	259.1	0.91	88.0	1485	62.0	0.77	88.0	985
176	35	315L	2955	313.0	0.91	88.0	1485	74.0	0.77	88.0	1152

High Speed	Low Speed	High Speed					Low Speed				Weight of motor (Kgs)
KW	KW	Frame	r/min	A	Cos	Eff%	r/min	A	Cos	Eff%	
1500/1000 RPM = 4/6 Poles											
Separate Windings - Y/Y											
0.55	0.18	80M	1410	1.5	0.71	68.0	920	0.57	0.58	62.0	15
0.75	0.25	90S	1420	1.8	0.73	70.0	920	0.95	0.66	63.0	18
1.1	0.36	90L	1420	2.8	0.78	72.0	920	1.0	0.66	68.0	22
1.5	0.5	100L1	1420	3.5	0.81	72.0	920	1.6	0.66	68.0	31
2.2	0.75	100L2	1420	5.0	0.78	81.0	920	2.3	0.67	74.0	32
3.0	1.0	112M	1420	6.3	0.82	81.0	920	2.9	0.68	75.0	42
4	1.3	132S	1440	8.1	0.83	81.0	940	3.5	0.68	75.0	56
5.5	1.8	132M	1450	11.2	0.88	81.0	970	4.6	0.75	75.0	70
7.5	2.5	160M	1450	14.8	0.88	83.0	970	6.2	0.76	77.0	106
11	3.5	160L	1450	21.5	0.88	84.0	970	8.3	0.78	78.0	130
15	5	180L	1460	28.3	0.90	85.0	980	11.7	0.77	80.0	176
18.5	6.1	200L1	1470	36.1	0.86	86.0	980	13.9	0.78	81.0	230
22	7.3	200L2	1470	42.4	0.86	87.0	980	16.5	0.78	82.0	231
33	11	225M	1470	61.5	0.88	88.0	990	22.5	0.84	84.0	309
45	15	250M	1470	80.1	0.88	88.0	990	29.5	0.85	85.0	412
55	18	280M	1480	97.9	0.89	90.0	990	35.2	0.87	85.0	576
75	25	315S	1480	132.0	0.90	91.0	990	47.5	0.87	87.0	889
90	30	315M	1480	154.0	0.91	91.0	990	58.8	0.80	89.0	982
110	36	315L1	1480	183.8	0.91	92.0	990	70.1	0.80	90.1	1152
132	44	315L2	1480	285.2	0.92	92.2	990	87.9	0.80	90.0	1153

* Data are for reference only

DBA Series , 2 Speed , Pole change

High Speed	Low Speed	High Speed					Low Speed				Weight of motor (Kgs)
KW	KW	Frame	r/min	A	Cos	Effi%	r/min	A	Cos	Effi%	
1500/750 RPM = 4/8 Poles											
Separate Windings - Y/Y											
0.6	0.12	80M1	1380	1.7	0.82	69.0	650	0.7	0.59	46.0	15
0.8	0.16	90S	1390	2.0	0.83	70.0	690	0.8	0.62	54.0	18
1.2	0.24	90L	1400	3.0	0.83	70.0	690	1.1	0.63	55.0	22
1.7	0.34	100L1	1400	4.0	0.80	80.0	690	1.8	0.61	63.0	31
2.4	0.48	100L2	1400	5.4	0.81	80.0	690	2.1	0.61	64.0	32
3.3	0.7	112M	1400	6.8	0.84	83.0	690	2.7	0.61	66.0	42
4.4	0.9	132S	1440	9.23	0.86	80.0	720	3.13	0.62	67.0	56
6.1	1.2	132M	1440	12.5	0.86	82.0	720	4.0	0.63	69.0	70
8.3	1.7	160M	1440	16.6	0.86	84.0	720	5.1	0.65	74.0	106
12	2.4	160L	1450	23.7	0.86	85.0	720	7.1	0.65	75.0	130
17	3.4	180M	1460	32.0	0.90	85.0	730	8.4	0.76	77.0	162
20	4	180L	1460	37.7	0.90	85.0	730	9.9	0.76	77.0	176
24	5	200L	1460	44.7	0.87	89.0	720	13.5	0.67	80.0	230
33	6.6	225S	1460	60.8	0.87	90.0	730	16.9	0.68	83.0	278
41	8.2	225M	1470	75.1	0.88	91.0	730	18.2	0.64	88.0	309
50	10	250M	1470	84.8	0.87	91.0	720	26.2	0.66	88.0	412
61	12	280S	1480	108.1	0.90	91.0	730	28.1	0.66	88.0	501
83	17	280M	1480	145.1	0.92	91.0	730	35.8	0.79	90.0	576
99	20	315S	1480	171.2	0.93	91.0	730	43.8	0.79	90.0	889
121	24	315M	1480	210.5	0.93	92.0	730	50.0	0.82	90.0	982
145	29	315L1	1480	261.4	0.93	92.0	730	61.5	0.82	91.0	1152
176	35	315L2	1480	312.0	0.93	92.0	730	72.8	0.82	91.0	1153

High Speed	Low Speed	High Speed					Low Speed				Weight of motor (Kgs)
KW	KW	Frame	r/min	A	Cos	Effi%	r/min	A	Cos	Effi%	
1000/750 RPM = 6/8 Poles											
Separate Windings - Y/Y											
0.55	0.24	90S	910	1.7	0.75	71.0	690	0.94	0.62	57.0	18
0.75	0.32	90L	910	2.0	0.75	71.0	690	1.1	0.62	57.0	22
1.1	0.47	100L	910	3.2	0.73	71.0	690	2.0	0.60	62.0	31
1.5	0.65	112M	910	4.0	0.73	74.0	690	2.1	0.60	66.0	42
2.2	0.95	132S	910	5.4	0.73	74.0	690	3.2	0.61	67.0	56
3	1.3	132M1	940	7.0	0.76	80.0	700	4.2	0.60	73.0	70
4	1.7	132M2	940	9.9	0.76	80.0	700	5.1	0.60	76.0	71
5.5	2.4	160M	940	11.4	0.76	82.0	700	7.0	0.60	77.0	106
7.5	3.2	160L	940	14.5	0.76	84.0	700	6.7	0.61	82.0	130
11	4.7	180L	940	21.4	0.77	86.0	700	12.3	0.63	82.0	176
13	5.5	200L	960	25.6	0.79	86.0	710	13.1	0.66	82.0	230
15	6.5	225S	960	29.1	0.83	88.0	710	15.2	0.67	82.0	278
21	9	225M	960	39.8	0.83	88.0	710	21.2	0.70	83.0	309
26	11	250M	970	50.3	0.83	89.0	720	24.5	0.78	87.0	412
30	13	280S	970	55.8	0.83	90.0	720	25.8	0.78	87.0	501
37	16	280M	970	77.9	0.86	91.0	720	30.8	0.78	87.0	576
53	23	315S	980	99.5	0.86	91.0	730	49.8	0.81	89.0	889
65	28	315M	980	119.1	0.86	91.0	730	54.3	0.81	89.0	982
80	34	315L1	980	159.1	0.84	91.0	730	68.6	0.78	90.0	1152
92	40	315L2	980	179.5	0.85	92.0	730	81.5	0.80	91.0	1153

* Data are for reference only

Motors for hazardous areas

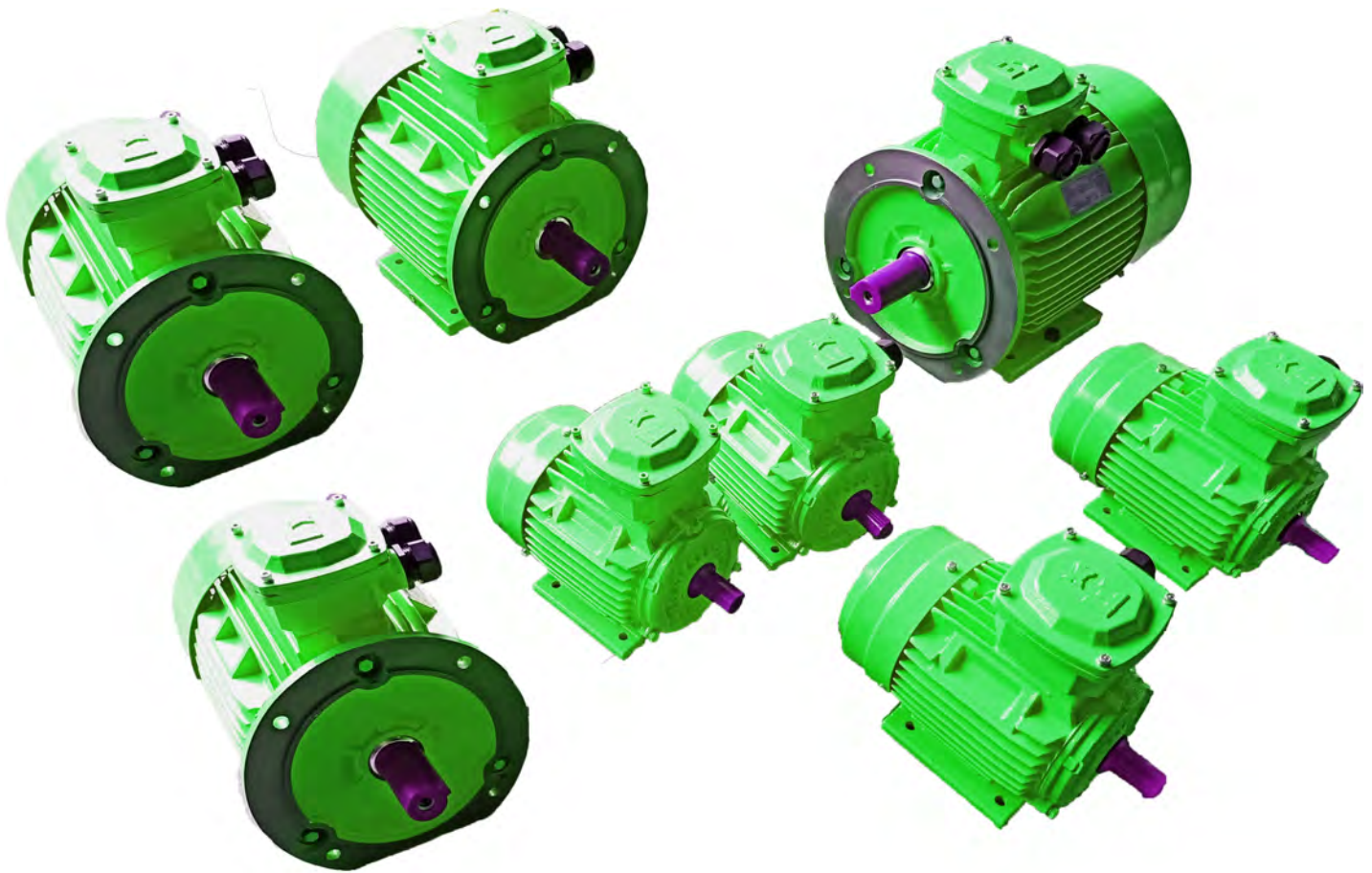

DBAE/DBAN/DBAtc/DBAtb

Motors used within a hazardous location require a higher level of protection against the risk of harmful occurrences. CMP DBA motors are available in the three most common high protection configurations, Ex e, Ex nA (formerly Ex n) and Ex tc / Ex tb (formerly DIP), supplied with protection ratings IP65 or IP66. DBA Hazardous area motors are available in motor frame sizes 80 to 355. Combinations of protection such as Ex e and Ex tb or Ex nA and Ex tc are also available.



European standards 'EN' series are closely aligned with IEC standards. They share the same numbering and require assessment and certification to ATEX directives, issued by the European Union.

The ATEX directive (2014/34/EC) addresses both the compliance of hazardous area equipment to specified standards, and the compliance to EH&SR (Essential Health & Safety Requirements).

Hazardous area certification

DBA motors in frames 80 to 355 are certified for use in hazardous locations as per ATEX requirements.

The following certificates are currently available:

ATEX

ECM 21 ATEX-B DO51	Exe, Ex eb / Ex tb
ECM 21 ATEX-B DO52	Ex nA, Ex ec / Ex tc

Motor protection types

DBAE - Ex e

Ex e motor protection designates Increased safety as outlined in IEC, EN 60079-7:2014

The increased safety (Ex e) type of protection describes electrical equipment that does not produce arcs or sparks in normal service in which additional measures are applied so as to give increased security against the possibility of excessive temperatures and of the occurrence of arcs and sparks.

Increased safety (Ex e) motors are suitable for Class I, Zone 1, Group II (A,B&C) hazardous areas, and Regal Australia provides for a temperature class of T3 (200°C) in a 40°C ambient (see next page for explanations of classes, zones and groups).

Ex e Protection - t_E time

t_E time is the time it takes for the stator winding or rotor cage to heat up from normal operating temperature, at the highest permitted ambient temperature, to the highest permitted limit temperature (temperature class), with the rotor locked and the stator winding loaded with the starting current.

Motors for hazardous areas

DBAN - Ex nA (formerly Ex n)

Ex nA motor protection designates Non-sparking as outlined in IEC, EN 60079-15:2014. Non-sparking (Ex nA) type of protection describes electrical equipment that, in normal operation, is not capable of igniting a surrounding explosive atmosphere, and a fault capable of causing ignition is not likely to occur.

Non-sparking (Ex nA) motors are suitable for Class I, Zone 2, Group II (A,B&C) hazardous areas, and Regal Australia provides for a temperature class of T3 (200°C) in a 50°C ambient.

Hazardous area classifications

Hazardous areas fall into two categories; hazards due to flammable gases (vapors or mists), and hazards due to combustible dusts (fibres or particles).

Gaseous hazards

Explosive gas atmospheres are classified into zones based on the frequency and duration of their occurrence as below:

Zone 0: an area in which an explosive gas atmosphere is present continuously, for long periods, or is present frequently.

Zone 1: an area in which an explosive gas atmosphere is likely to occur in normal operation occasionally.

Zone 2: an area in which an explosive gas atmosphere is not likely to occur in normal operation, and if it does occur it will exist for a short period only.

Electrical apparatus for potentially explosive atmospheres is divided into the following groups:

Group I: mines susceptible to fire damp (methane).

Group II: other industries.

High surface temperatures can cause ignition of flammable gases or vapors therefore the surface temperature of equipment in hazardous areas must not exceed the ignition temperature of these gases or vapors.

Group I electrical equipment may not have a surface temperature that exceeds 150°C where coal dust can form a layer, and 450°C for internal surfaces where the above risk is avoided by sealing against ingress or dust.

Group II electrical equipment may not have a surface temperature that exceeds its specified temperature class, as listed in the table below:

Temperature class of electrical equipment	Maximum surface temperature of electrical equipment	Ignition temperature of gas or vapor
T1	≤ 450°C	> 450°C
T2	≤ 300°C	> 300°C
T3	≤ 200°C	> 200°C
T4	≤ 135°C	> 135°C
T5	≤ 100°C	> 100°C
T6	≤ 85°C	> 85°C

DBAtc - Ex tc / DBAtb - Ex tb (formerly dIP)

Ex tc / Ex tb motor protection designates dust-excluding ignition proofing as outlined in IEC or AS/NZS61241 series of standards.

Dust-excluding ignition proofing (Ex tc / Ex tb) type of protection describes electrical equipment which is enclosed so that it excludes dust, and which will not permit arcs, sparks or heat otherwise generated or liberated inside the enclosure to cause ignition of exterior accumulations or atmospheric suspensions of a specific dust on or in the vicinity of the enclosure.

Dust-excluding ignition proofed (Ex tc / Ex tb) motors are suitable for Zone 21 or 22 dust laden hazardous areas, and CMP provides for a temperature class of T4 (135°C) in a 50°C ambient.

combustible dust hazards

Many dusts which are generated, processed, handled and stored, are combustible. When ignited, they can burn rapidly and with considerable explosive force if mixed with air in the appropriate proportions. Electrical apparatus used in locations where this hazard is present, requires adequate protection so as to reduce the likelihood of ignition of the external explosive atmosphere.

Areas where dusts, flyings and fibres in air occur in dangerous quantities are classified as hazardous and are divided into three zones according to the level of risk.

Zone 20: An area in which combustible dust, as a cloud, is present continuously or frequently during normal operation, in sufficient quantity to be capable of producing an explosive dust/air mixture, and/or where layers of dust of uncontrollable and excessive thickness can be formed.

Zone 21: An area not classified as Zone 20 in which combustible dust, as a cloud, is likely to occur during normal operation, in sufficient quantities to be capable of producing an explosive dust/air mixture.

Zone 22: An area not classified as Zone 21 in which combustible dust clouds may occur infrequently, and persist for only a short period, or in which accumulations or layers of combustible dust may be present under abnormal conditions and give rise to combustible dust/air mixtures. Where, following an abnormal condition, the removal of dust accumulations or layers cannot be assured then the area is to be classified.

Zones -ATEX

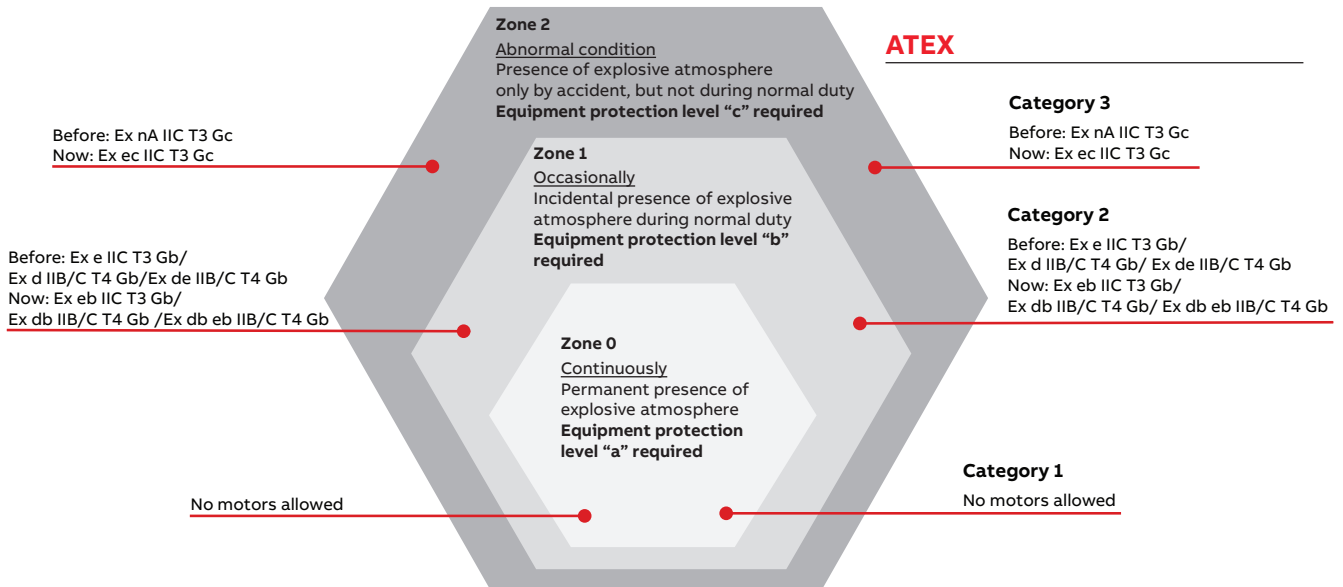

Note: Based on traditional relationship between EPL`s and zones.

There are systems in place worldwide to classify explosive atmospheres by zones, according to the risk posed by explosive gas ("G") or dust ("D").

Classification of explosive atmospheres according to CENELEC and IEC

The following standards define areas according to the presence of gas or dust in the atmosphere:

- IEC/EN 60079-10-1 Gas
- IEC/EN 60079-10-2 Dust

Standard IEC 60079-0 EN 60079-0 Group	EPL	Protection level	Installation Zone acc. to IEC 60079-10-x EN 60079-10-x Zones	ATEX Directive 2014/34/EU Equipment group	Equipment category	Main motor protection types
I (Mines)	Ma	very high	NA	I (Mines)	M1	NA
	Mb	high			M2	
II (Gas)	Ga	very high	0	II (Surface)	1G	NA
	Gb	high	1		2G	Ex d/Ex de Ex p, Ex db, Ex db eb, Ex p, Ex eb (Ex e)
	Gc	enhanced	2		3G	Ex ec (Ex nA)
III Dust	Da	very high	20		1D	NA
	Db	high	21		2D	Ex tb IP 65
	Dc	enhanced	22		3D	Ex tc IP 65/IP 55

Motors for hazardous areas

Motor Terminal Box and Cable Entry

- Standard terminal box is mounted on the Top. Motors are also available with on the right hand

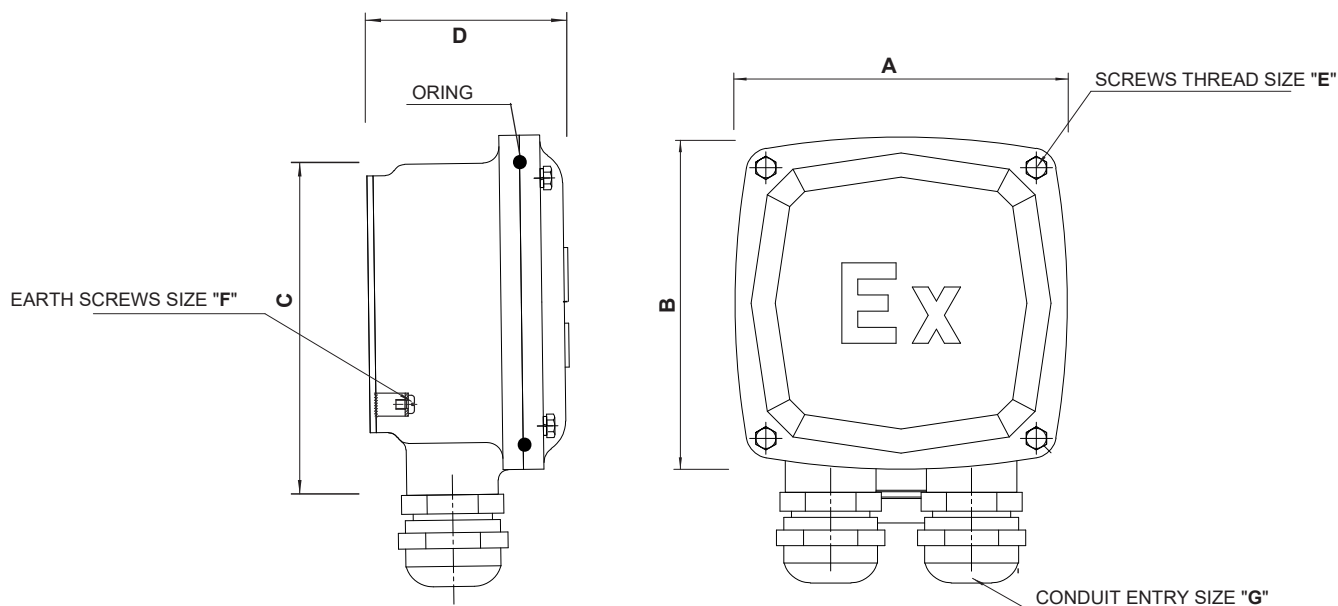

Frame Size	A	B	C	D	E	F	G
80	116	116	107	63	M4	M5	1-M25x1.5
90-100	116	116	107	63	M5	M5	1-M25x1.5
112-132	136	136	128	80	M5	M5	2-M32x1.5
160-180	165	165	162	95	M6	M5	2-M32x1.5
200-255	240	240	222	124	M8	M8	2-M40x1.5
250-280	295	295	290	148	M10	M10	2-M50x1.5
315	340	340	336	198	M16	M12	2-M63x1.5
355	420	420	400	230	M20	M12	2-M63x1.5

Dimensions & Mounting

B14 (small flange mounted)

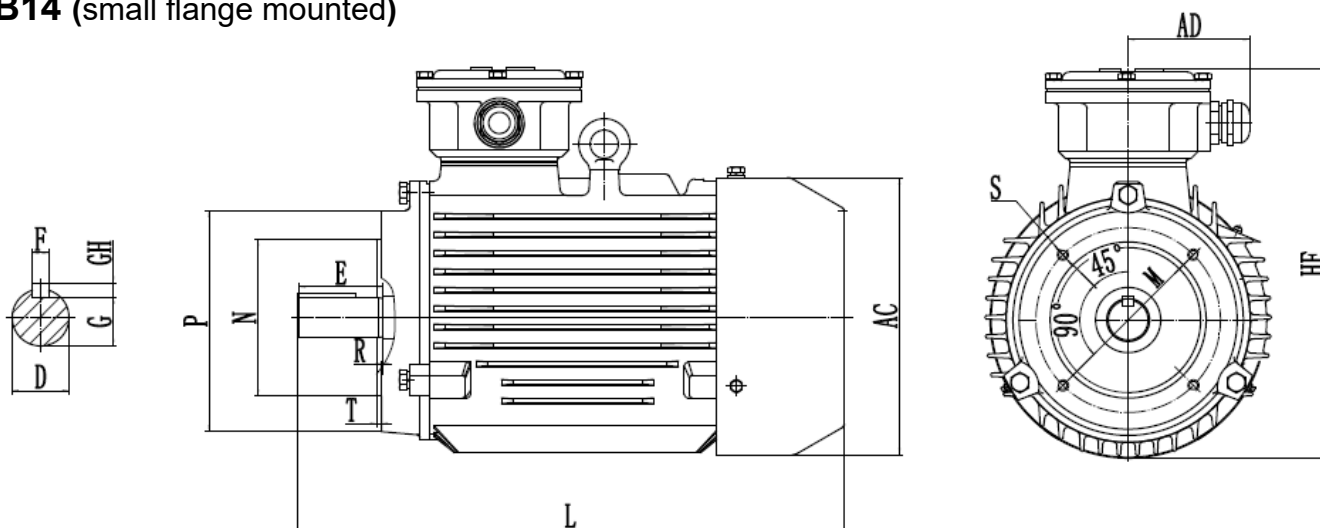

Frame	Poles	Mounting Dimension										Overall Dimension			
		D	E	F	G	M	N	P	R	S	T	AC	AD	HF	L
80M	2,4,6,8	19	40	6	15.5	100	80	120	0	4-M6	3	165	95	240	295
90S	2,4,6,8	24	50	8	20	115	95	140	0	4-M8	3	180	95	250	320
90L	2,4,6,8														345
100L	2,4,6,8	28	60	8	24	130	110	160	0	4-M8	3.5	205	95	280	390
112M	2,4,6,8	28	60	8	24	130	110	160	0	4-M8	3.5	225	115	315	425

Motors for hazardous areas

B3 (Horizontal foot mounted only)

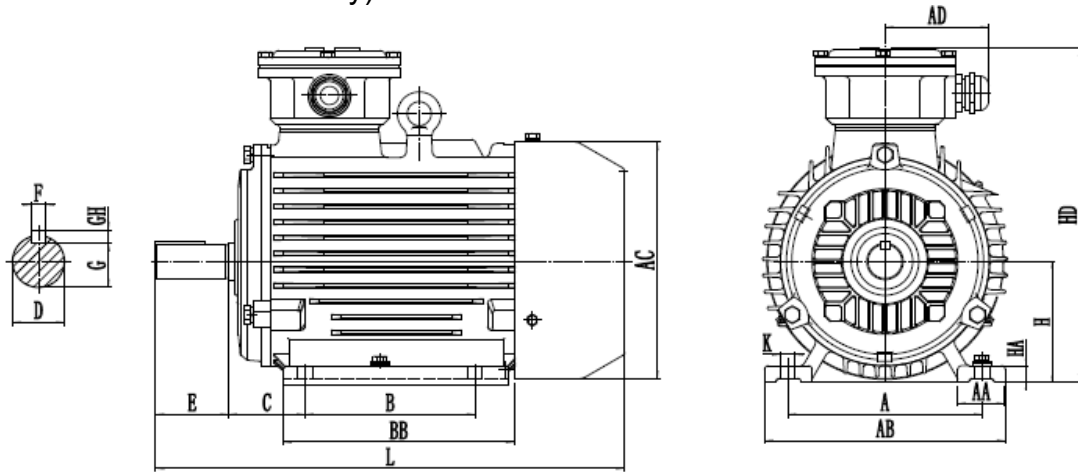

H80-132mm

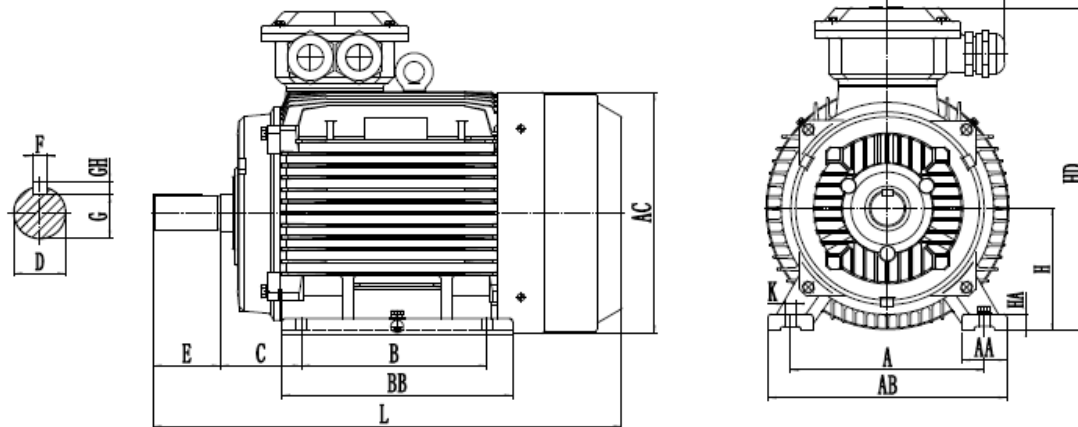

H160-355mm

Frame	Pole	Mounting Dimension									Overall Dimension							
		A	B	C	D	E	F	G	H	K	AA	BB	HA	AB	AC	AD	HD	L
80M	2.4.6.8	125	100	50	19	40	6	15.5	80	10	32	135	10	160	165	95	240	295
90S	2.4.6.8	140	100	56	24	50	8	20	90	10	34	145	12	180	180	95	255	320
90L			125															170
100L	2.4.6.8	160	140	63	28	60	8	24	100	12	39	186	14	200	205	95	285	390
112M	2.4.6.8	190	140	70	28	60	8	24	112	12	45	200	14	230	225	115	320	425
132S	2.4.6.8	216	140	89	38	80	10	33	132	12	55	190	18	265	270	115	410	475
132M			178									230						510
160M	2.4.6.8	254	210	108	42	110	12	37	160	15	65	260	20	315	320	136	430	610
160L			254									304						655
180M	2.4.6.8	279	241	121	48	110	14	42.5	180	15	70	311	22	355	360	136	480	680
180L			279									349						715
200L	2.4.6.8	318	305	133	55	110	16	49	200	19	74	379	26	395	400	190	540	770
225S	4.8	356	286	149	60	140	18	53	225	19	78	375	28	435	450	190	585	795
225M	2		311	149	55	110	16	49				400						800
	4.6.8		60	140	18	53	825											
250M	2	406	349	168	60	140	18	53	250	24	80	445	30	490	510	225	665	890
	4.6.8				65	140	18	58										
280S	2	457	368	190	65	140	18	58	280	24	90	485	35	545	550	225	710	970
	4.6.8				75	140	20	67.5										

Motors for hazardous areas

B3 (Horizontal foot mounted only)

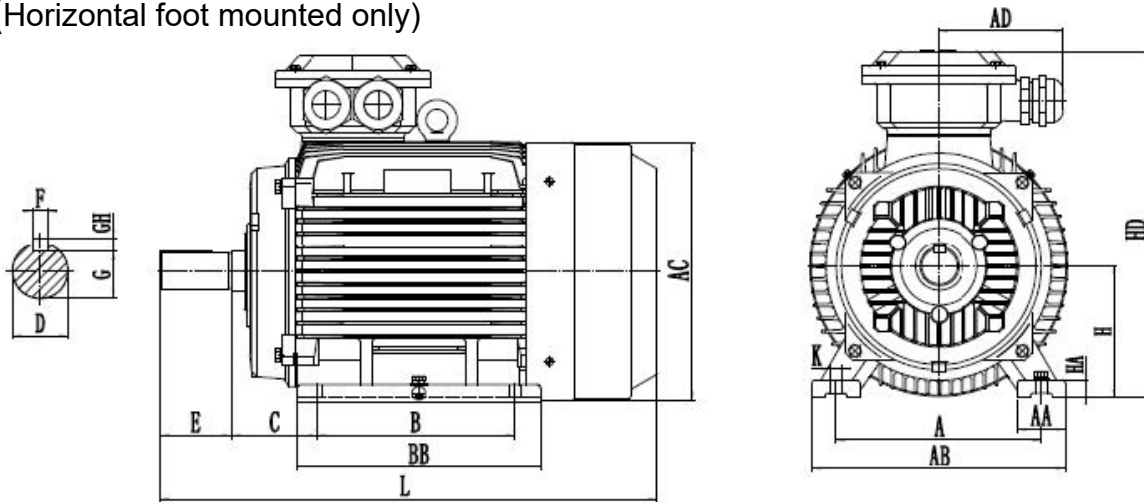

H160-355mm

Frame	Pole	Mounting Dimension									Overall Dimension																			
		A	B	C	D	E	F	G	H	K	AA	BB	HA	AB	AC	AD	HD	L												
280M	2	157	419	190	65	140	18	58	280	24	90	536	35	545	550	225	710	1025												
	4.6.8				75	140	20	67.5																						
315S	2	508	406	216	65	140	18	58	315	28	120	610	45	635	630	250	885	1180												
	4.6.8.10				80	170	22	71										1210												
315M	2				65	140	18	58										680	1215											
	4.6.8.10				80	170	22	71										1245												
315L	2	508	406	216	65	140	18	58	315	28	120	610	45	635	630	250	885	1290												
	4.6.8.10				80	170	22	71										1320												
355M	2	610	560	254	75	140	20	67.5	355	28	130	735	52	715	715	290	1040	1390												
	4.6.8.10				95	170	25	86										1420												
355L1	2				630	560	254	75										140	20	67.5	355	28	130	735	52	715	715	290	1040	1500
	4.6.8.10							95										170	25	86										1530
355L2	2	630	560	254	75	140	20	67.5	355	28	130	735	52	715	715	290	1040	1500												
	4.6.8.10				95	170	25	86										1530												

B5 (Flange mounted)

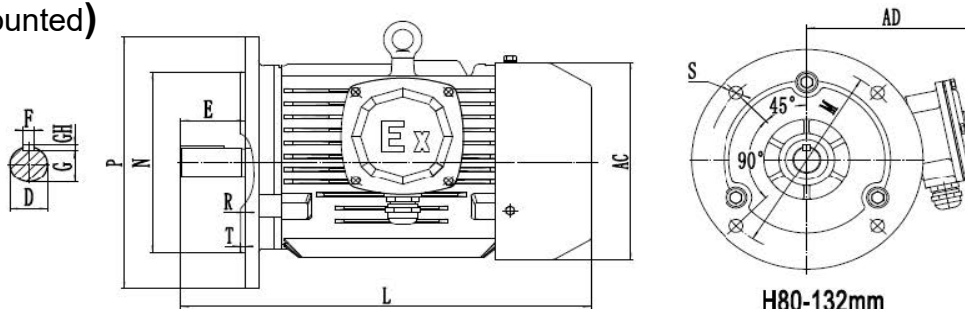

H80-132mm

Frame	Poles	Mounting Dimension										Overall Dimension			
		D	E	F	G	M	N	P	R	S	T	AC	AD	HF	L
80M	2.4.6.8	19	40	6	15.5	165	130	200	0	4-φ12	3.5	165	160	/	295
90S	2.4.6.8	24	50	8	20	165	130	200	0	4-φ12	3.5	180	165	/	320
90L															345
100L	2.4.6.8	28	60	8	24	215	180	250	0	4-φ15	4	205	180	/	390
112M	2.4.6.8	28	60	8	24	215	180	250	0	4-φ15	4	225	205	/	425
132S	2.4.6.8	38	80	10	33	265	230	300	0	4-φ15	4	270	240	/	475
132M															510

Motors for hazardous areas

B5 (Flange mounted)

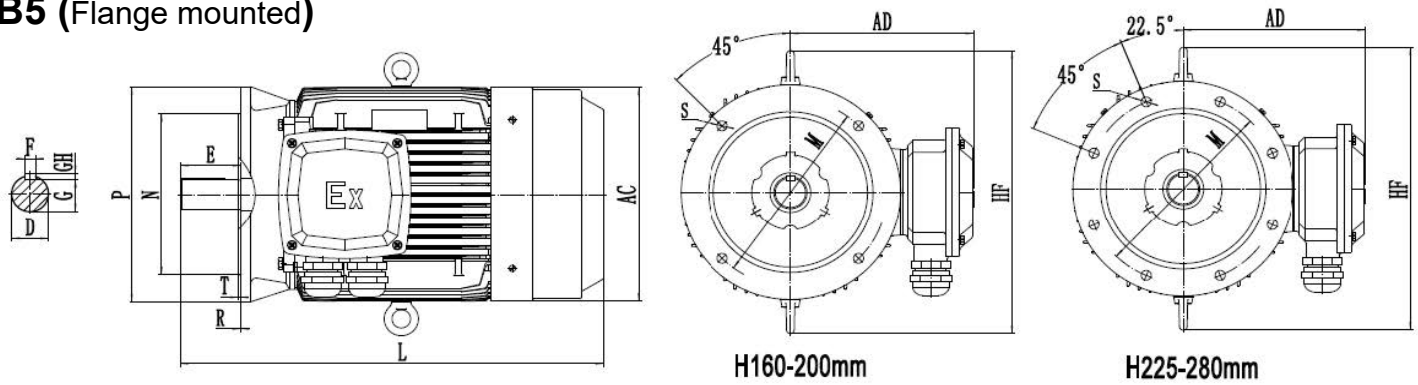

机座号 Frame	极数 Poles	安 装 尺 寸 Mounting Dimension										外形尺寸 Overall Dimension			
		D	E	F	G	M	N	P	R	S	T	AC	AD	HF	L
160M	2.4.6.8	42	110	12	37	300	250	350	0	4-φ19	5	320	270	435	610
160L															655
180M	2.4.6.8	48	110	14	42.5	300	250	350	0	4-φ19	5	360	285	490	680
180L															715
200L	2.4.6.8	55	110	16	49	350	300	400	0	4-φ19	5	400	335	550	770
225S	4.8	60	140	18	53	400	350	450	0	8-φ19	5	450	360	580	795
225M	2	55	110	16	49										800
		4.6.8	60	140	18	53	825								
250M	2	60	140	18	53	500	450	550	0	8-φ19	5	510	415	695	890
		4.6.8			58										
280S	2	65	140	18	58	500	450	550	0	8-φ19	5	550	435	725	975
		4.6.8		75	20										
280M	2	65		18	58										1025
		4.6.8		75	20										

B35 (Foot and Flange mounted)

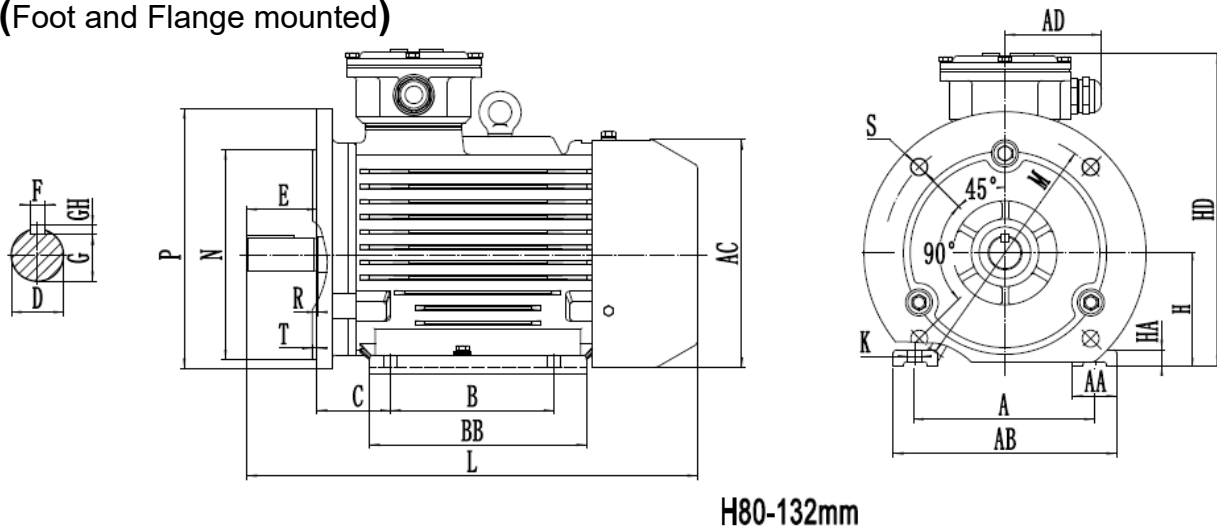

H80-132mm

Frame	Poles	Mounting Dimension														Overall Dimension									
		A	B	C	D	E	F	G	H	M	N	P	R	S	T	K	AA	BB	HA	AB	AC	AD	HD	L	
80M	2.4.6.8	125	100	50	19	40	6	15.5	80	165	130	200	0	4-φ12	3.5	10	32	130	10	160	165	95	240	295	
90S	2.4.6.8	140	100	56	24	50	8	20	90	165	130	200	0	4-φ12	3.5	10	34	145	12	180	180	95	255	320	
90L			125															170						345	
100L	2.4.6.8	160	140	63	28	60	8	24	100	215	180	250	0	4-φ15	4	12	39	186	14	200	205	95	285	390	
112M	2.4.6.8	190	140	70	28	60	8	24	112	215	180	250	0	4-φ15	4	12	45	200	14	230	225	115	320	425	
132S	2.4.6.8	216	140	89	38	80	10	33	132	265	230	300	0	4-φ15	4	12	55	190	18	265	270	115	410	475	
132M			178															230						510	

Motors for hazardous areas

B35 (Foot and B5 flange mounted)

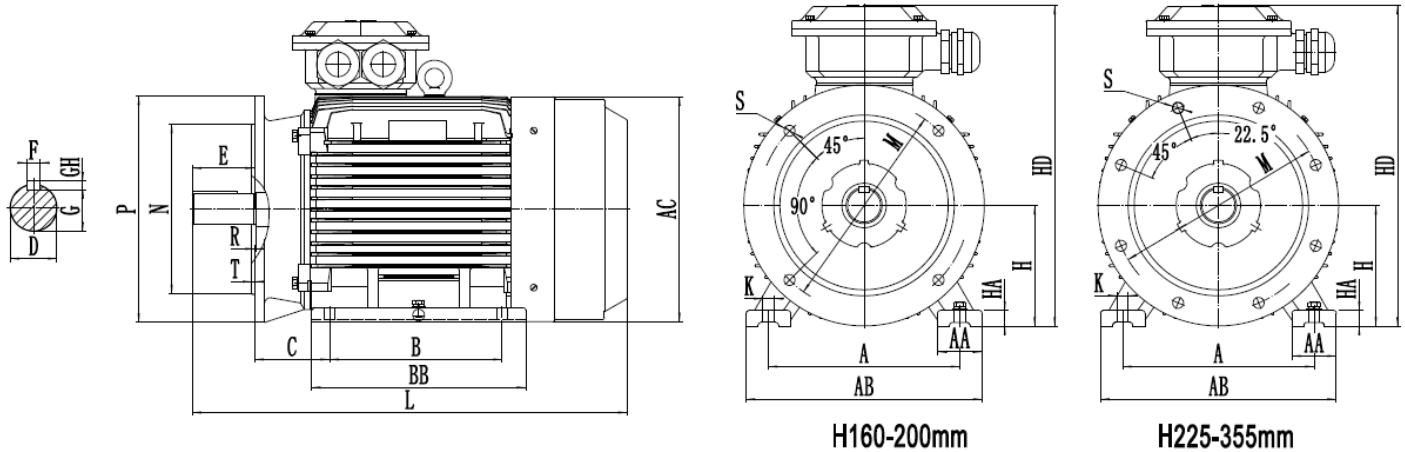

Frame	Poles	Mounting Dimension														Overall Dimension								
		A	B	C	D	E	F	G	H	M	N	P	R	S	T	K	AA	BB	HA	AB	AC	AD	HD	L
160M	2.4.6.8	254	210	108	42	110	12	37	160	300	250	350	0	4-φ19	5	15	65	260	20	315	320	136	430	610
160L			0										304					655						
180M	2.4.6.8	279	241	121	48	110	14	42.5	180	300	250	350	0	4-φ19	5	15	70	311	22	355	360	136	480	680
180L			0										349					715						
200L	2.4.6.8	318	305	133	55	110	16	49	200	350	300	400	0	4-φ19	5	19	74	379	26	395	400	190	540	770
225S	4.8	356	286	149	60	140	18	53	225	400	350	450	0	8-φ19	5	19	78	375	28	435	450	190	585	795
225M	2	356	311	149	55	110	16	49	225	400	350	450	0	8-φ19	5	19	78	400	28	435	450	190	585	800
	4.6.8				60	140	18	53																825
250M	2	406	349	168	60	140	18	53	250	500	450	550	0	8-φ19	5	24	80	445	30	490	510	225	665	890
	4.6.8				65	140	18	58																890
280S	2	457	368	190	65	140	18	58	280	500	450	550	0	8-φ19	5	24	90	485	35	545	550	225	710	975
	4.6.8				75	140	20	67.5										975						
280M	2	457	419	190	65	140	18	58	280	500	450	550	0	8-φ19	5	24	90	536	35	545	550	225	710	1025
	4.6.8				75	140	20	67.5										1025						
315S	2	508	406	216	65	140	18	58	315	600	550	660	0	8-φ24	6	28	120	570	45	635	630	250	885	1180
	4.6.8.10				80	170	22	71										1210						
315M	2	508	457	216	65	140	18	58	315	600	550	660	0	8-φ24	6	28	120	610	45	635	630	250	885	1215
	4.6.8.10				80	170	22	71										1245						
315L	2	508	457	216	65	140	18	58	315	600	550	660	0	8-φ24	6	28	120	680	45	635	630	250	885	1290
	4.6.8.10				80	170	22	71										1320						
355M	2	610	560	254	75	140	20	67.5	355	740	680	800	0	8-φ24	6	28	130	690	52	735	715	290	1040	1390
	4.6.8.10				95	170	25	86										1420						
355L1	2	610	560	254	75	140	20	67.5	355	740	680	800	0	8-φ24	6	28	130	750	52	735	715	290	1040	1500
	4.6.8.10				95	170	25	86										1530						
355L2	2	610	560	254	75	140	20	67.5	355	740	680	800	0	8-φ24	6	28	130	750	52	735	715	290	1040	1500
	4.6.8.10				95	170	25	86										1530						

Motors for hazardous areas

V1 (Vertical shaft down footless flange mounted)

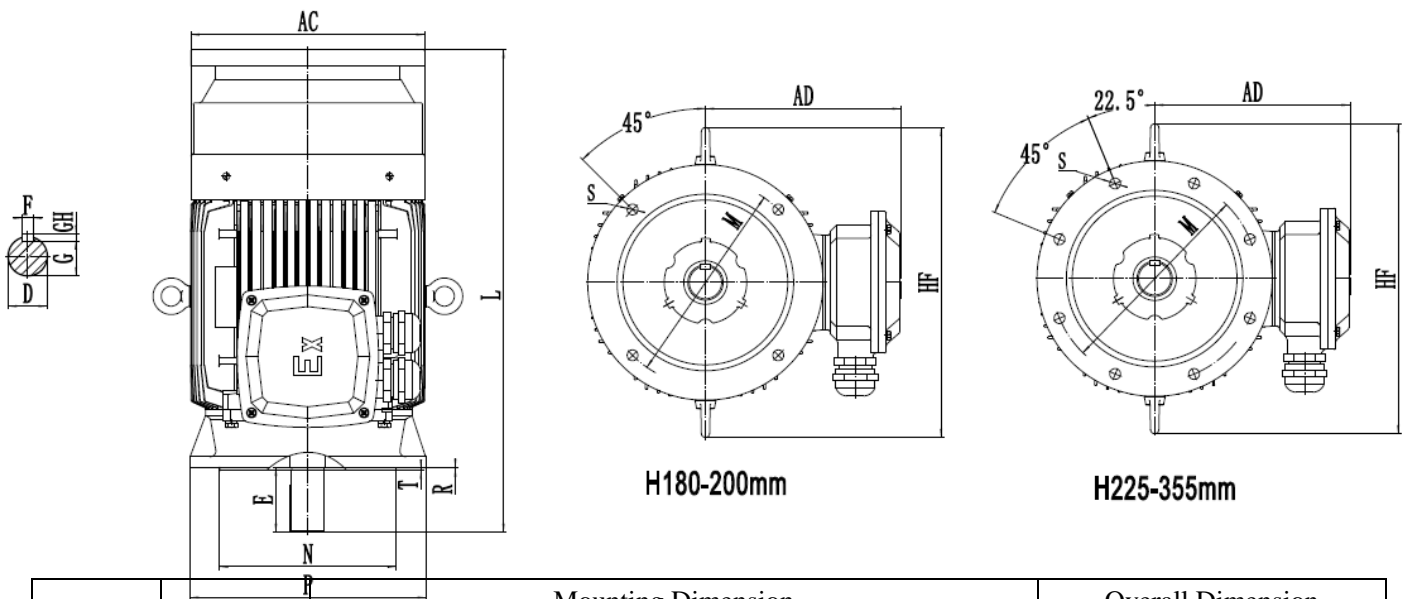

Frame	Poles	Mounting Dimension										Overall Dimension			
		D	E	F	G	M	N	P	R	S	T	AC	AD	HF	L
180M	2,4,6,8	48	110	14	42.5	300	250	350	0	4-Φ19	5	360	285	490	725
180L															765
200L	2,4,6,8	55	110	16	49	350	300	400	0	4-Φ19	5	400	335	550	825
225S	4,8	60	140	18	53	400	350	450	0	8-Φ19	5	450	360	580	855
225M	2	55	110	16	49										860
		4,6,8	60	140	18	53	885								
250M	2	60	140	18	53	500	450	550	0	8-Φ19	5	510	380	695	955
		4,6,8			65										
280S	2	65	140	18	58	500	450	550	0	8-Φ19	5	550	395	725	1045
		4,6,8		75	20										
280M	2	65		18	58										1100
		4,6,8		75	20										
315S	2	65	140	18	58	600	550	660	0	8-Φ24	6	630	565	860	1310
		4,6,8,10	80	170	22										71
315M	2	65	140	18	58										1345
		4,6,8,10	80	170	22										71
315L	2	65	140	18	58	1420									
		4,6,8,10	80	170	22	71	1450								
355M	2	75	140	20	67.5	740	680	800	0	8-Φ24	6	715	680	980	1530
		4,6,8,10	95	170	25										86
355L1	2	75	140	20	67.5										1640
		4,6,8,10,	95	170	25										86
355L2	2	75	140	20	67.5	1640									
		4,6,8,10	95	170	25	86	1670								

CMP - A Global Promise !



**HEAD OFFICE -
AUSTRALIA**

CMP ELECTRIC MOTOR (AUSTRALIA) PTY LTD
12 Treetops Avenue South Penrith
2750 Sydney N.S.W
email : sales@cmpmotor.com
www.cmpmotor.com

MALAYSIA

CMP ELECTRIC MOTOR(ASIA PACIFIC) SDN BHD
No.2-28, Jalan Puteri 4/8,Bandar Puteri, 47100
Puchong,
Selangor,Malaysia.
email: louis.lim@cmpmotor.com

NEWTON AUTOMATION (M) SDN BHD
No.22,Jalan Permata 9A/KS09,Taman Perindustrian
Air Hitam,41200 Klang,Selangor ,Malaysia.
email: sales@newton-group.net

INDONESIA

PT CMP INDONESIA
Kapuk Ecopark Unit B1,Jl. Kapuk Kamal Raya
No.45RT.
012 RW.001 Kel.Kamal Muara Kec.Penjaringan
Jakarta
Utara DKI,Jakarta 14470, Indonesia.
email: marketing@cmpindonesia.com

SINGAPORE

RPM ELECTRICAL ENGINEERING PTE LTD
No 1, Joo Koon Way, Gate 2,Singapore 628942.
email: rpmeep1@singnet.com.sg

THAILAND

HINERGY CO.,LTD
1213/439, Noble Tara Village,Ekamai Rama 9,
Ladprao 94 Plubpla Wangthonglang ,Bangkok
10310 ,Thailand.
email: sales@hinergy.co.th

PHILIPPINES

email: john.anthony@cmpmotor.com

HONG KONG & MACAO CHINA

A-TECH ENGINEERING CO.,LTD
Unit 2404,24/F., World-Wide House,19 Des
Voeux Road, Central, 999077Hong Kong.
email: darren@a-techeng.com

KOREA

CMP KOREA
No.12-1, Sankokdong-Ro, 32 Beon Gil,
Hanam-Si, Gyeonggi-do, Republic of
Korea.
email: johnahn@cmpkorea.com